



**supremeSchwank Series    IO-200 Series Models:**  
**Models: 2312; 2313; 2352            IO-212; IO-213; IO-252**

All models approved:

- ANSI Z83.26-2014 / CSA 2.37-2014
  - Gas-Fired Infrared Patio Heater for Outdoor Commercial / Residential Application
- ANSI Z83.19a-2011 / CSA 2.35a-2011
  - Gas-Fired High Intensity Infrared Heater for Commercial /Industrial Non-Residential Application for either indoor or outdoor installation

All models constructed with Marine Grade Stainless Steel Cabinet



**INSTALLATION / OWNER'S MANUAL**



**WARNING**

Improper installation, adjustment, alteration, service or maintenance can cause property damage, injury or death.

Read the installation and operating and maintenance instructions thoroughly before installing or servicing this equipment.



**SAFETY ALERT:**

This heater must be installed and serviced only by a trained gas service technician. Failure to comply could result in personal injury, death, fire and/or property damage.

Do not store or use gasoline or other flammable vapors and liquids in the vicinity of this or any other gas fired appliance.

**Indoor Applications: The heater cannot be used indoors in a residence.**



**IF YOU SMELL GAS:**

- Extinguish any open flame
- Do not attempt to light this or any other appliance
- Don't touch any electrical switch, or telephone
- Immediately leave the area and call your gas supplier from a neighbor's phone
- Follow any and all instruction from your gas supplier
- If your gas supplier is not available, call the fire department



**FIELD CONVERTIBILITY:**

This appliance is field convertible to LP gas [except 2352/IO-252: NG only].  
 Only use kit available from manufacturer.  
 Follow kit instructions and all local and national codes.

**INSTALLER: PRESENT THIS MANUAL TO THE END USER.**  
**Keep this manual in a secure place.**  
*Record for future reference:*

Model #: \_\_\_\_\_

Serial #: \_\_\_\_\_

*[located on heater rating label]*

**GAS-FIRED**

**C UL US LISTED**

2300 / IO 210 Manual  
 IM110107  
 RD: SEPT 2021  
 R.L. 21A

**NOTICE:**

*The manufacturer reserves the right to make changes to equipment and specifications without obligation or notification.*

*This publication, or parts thereof, may not be reproduced in any form, without prior written consent from the manufacturer  
Unauthorized use or distribution of this publication is strictly prohibited.*

**Schwank Group**

2 Schwank Way  
Waynesboro, Georgia,  
USA 30830

6485 Ordan Dr  
Mississauga, Ontario  
L5T 1X2

**Technical Support & Customer Service:**

Phone: 1-877-686-3779 OR 706-554-6191

Fax: 1-866-361-0523

e-mail: [csr@schwankgroup.com](mailto:csr@schwankgroup.com)

Complete product information:

**[www.schwankgroup.com](http://www.schwankgroup.com)**

**[www.InfraSave.com](http://www.InfraSave.com)**

**Models: 2312; 2313; 2352 / IO-212; IO-213; IO-252**

Gas-fired Infrared Patio Heater for Outdoor Commercial / Residential Application, and Gas-Fired Luminous [High Intensity] Infrared Heater for Commercial / Industrial Non-Residential Application for either indoor or outdoor installation

**TABLE OF CONTENTS**

TOPIC	PAGE NUMBER	TOPIC	PAGE NUMBER
<b>⚠ IMPORTANT INFORMATION - READ FIRST</b>			
<b>IMPORTANT WARNINGS</b> .....	4	8. ELECTRICAL - BASIC REQUIREMENTS .....	14
<b>HEATER EXPANSION</b> .....	5	9. INSTALLATION PROCEDURES .....	15
<b>GAS CONNECTION</b> .....	5	10. LIGHTING INSTRUCTIONS .....	16
<b>VENTING</b> .....	5, 13	10.1 SHUT DOWN INSTRUCTIONS .....	16
<b>'SMOKE' &amp; DISCOLORATION</b> .....	5	11. HEATER FINISH & APPEARANCE .....	16
<b>MOUNTING &amp; CLEARANCE DISTANCES:</b>		12. SERVICING GUIDE .....	17
<b>OUTDOOR PATIO INSTALLATION</b> .....	6	13. VENTILATION FOR INDOOR APP'S.....	19
<b>INDOOR INSTALLATION</b> .....	9	14. DIMENSIONS & CONFIGURATION .....	20
1. APPLICATION.....	11	15. MOUNTING KIT OPTIONS.....	21
OUTDOOR / PATIO.....	11	16. ELECTRICAL REQUIREMENTS.....	26
INDOOR INSTALLATION .....	11	16.1 CONTROL OPTIONS.....	26
2. AIRCRAFT HANGARS.....	12	17. SEQUENCE OF OPERATION-FENWAL 35-60	
3. GARAGES & PARKING STRUCTURES.....	12	DSI.....	27
4. OTHER THAN SPACE HEATING .....	12	18. SPARK IGNITION CIRCUIT .....	28
5. PRE-INSTALLATION SURVEY .....	12	19. WIRING DIAGRAM .....	29
6. INSTALLATION REQUIREMENTS .....	13	20. TROUBLESHOOTING GUIDE.....	32
6.1 MOUNTING CLEARANCES.....	13	21. COMMISSIONING REPORT .....	34
6.2 HEATER MOUNTING .....	13	22. HIGH ALTITUDE INSTALLATION .....	36
7. GAS SUPPLY PIPING.....	14	23. REPLACEMENT PARTS LIST.....	37 - 42
7.1 GAS PRESSURE .....	14	24. LIMITED WARRANTY.....	43



**IMPORTANT**

**Installer:** Present this manual to the end user. Acquaint the end user with Important Information: Cover & pages 4 to 10.



**END USER:** In particular you must be aware of 'Clearances to Combustible' requirements and the limitations of stacking or placing material near the heaters.

Inform your safety personnel and staff of this information.



## WARNING



Improper installation, adjustment, alteration, service or maintenance can cause property damage, injury or death. Read and understand this installation and operation manual thoroughly prior to assembly, installation, operation or service to this appliance.

This heater must be installed and serviced only by a trained gas service technician.



Do not store or use gasoline or other flammable vapours and liquids in the vicinity of this or any other gas fired appliance.

Failure to comply to these warnings could result in personal injury, death, fire and/or property damage.



This appliance may have sharp edges and corners. Wear protective clothing such as gloves and protective eye wear when servicing this or any other appliance.

California Proposition 65:



**WARNING:** This product can expose you to chemicals including carbon monoxide, which is known to the State of California to cause birth defects or other reproductive harm. For more information, go to [www.P65Warnings.ca.gov](http://www.P65Warnings.ca.gov)



## WARNING

**DO NOT INSTALL THIS APPLIANCE IN A RECESS, ALCOVE, OR ENCLOSURE.**

While minimum clearances to combustibles are stipulated to ensure safe installation, adequate free space must be provided to allow the products of combustion to escape from the heater to atmosphere when installed outdoors, or through mechanical exhaust withdrawal when installed indoors. Also refer to “Outdoor” and “Indoor” definitions and requirements on page 11.



## WARNING

Due to the effects of radiant heat upon certain materials it is not recommended to store or place items that could be damaged or distorted, directly under this heater...i.e. combustible patio furniture etc.

- Clothing or other flammable materials should not be hung from, or placed near to the heater
- Children and Adults should be alerted to the hazards of high surface temperatures and should be careful to avoid burns or clothing ignition
- Young children should be carefully supervised when in the area of a heater



## WARNING

This heater is not for installation in a Class 1 or Class 2 explosive environment, nor for any residential application. If installation of this equipment is in question, consult with local authorities having jurisdiction [Fire Marshal, labor department, insurance underwriter, or others].

Revisions to codes and/or standards, may require revision to equipment and installation procedures. In case of discrepancy, the latest codes, standards, and installation manual will take priority over prior releases.

**IMPORTANT: DO NOT INSTALL THIS HEATER INDOORS IN A STRUCTURE WITH NO INSULATION IN THE ROOF—CONDENSATION WILL OCCUR.**



## WARNING

### Heater Expansion



It is a normal condition that during heat-up and cool-down a radiant heater will expand and contract. Allowances for heater expansion must be made in the gas connection and heater suspension. Improper installation, alteration, or adjustment can result in property damage, injury or death.



## WARNING

### Gas Connection



Improper installation, connection, or adjustment can result in property damage, toxic gases, asphyxiation, injury or death. Use an approved stainless steel flexible gas connector [field supplied] to connect to the gas supply to the heater in accordance with all local, state, provincial, and national codes [ANSI Z223.1/NFPA 54 in USA; B149.1 in Canada] and as indicated in this manual.



## WARNING

### Venting



Inadequate venting of a heater may result in asphyxiation, carbon monoxide poisoning, injury or death. When used indoors, this heater is indirectly vented from the space. Venting must be in accordance with all local, state, provincial, and national codes [ANSI Z223.1/NFPA 54 in USA; B149.1 in Canada] and as indicated in this manual. **Refer to Page 19**



## WARNING

### Start-up 'Smoke' & Discoloration Condition

During start-up, the heating of material coatings used in the production process of the heater may create a small amount of smoke during the initial period of operation. This condition is normal and temporary .

Ensure that there is sufficient ventilation to adequately clear any 'smoke' from the space.

*Notify site management and safety personnel to ensure that alarm systems are not unduly activated.*

## WARNING

### Heater Discoloration / Staining

**Stainless Steel & Painted Finishes:** Surface discoloration or staining will occur on any heater body due to heat. Surface finish discoloration due to heat is a normal occurrence. Surface discoloration does not affect the operation or performance of the heater nor the manufacturer's component warranties. [Refer to Section 11: Heater Finish & Appearance, page 16]

Some discoloration can result from the deposit of ambient air-borne particulate or gases from within the space that have passed through combustion to create 'smoke'. The combustion of fuel gas in a clean environment will not cause smoke discoloration deposits.

---

## WHEN INSTALLED AS AN OUTDOOR PATIO HEATER

- See pages 9 - 10 for Indoor installation, and Ventilation Requirements page 19
- Also refer to “Outdoor” and “Indoor” definitions and requirements on page 11



### WARNING

Certain materials or items, when stored under the heater, will be subjected to radiant heat and could be seriously damaged.

Location of flammable or explosive objects, liquids or vapors close to the heater may cause fire or explosion and result in property damage, injury or death. Do not use, store or locate flammable or explosive objects, liquids or vapors in proximity of the heater.



**The clearance to combustible material represents the minimum distance that must be maintained between the outer heater surface and a nearby surface. The stated clearance to combustibles represents a surface temperature of 117F° [65C°] above ambient temperature when installed outdoors.**



**It is the installer’s responsibility to ensure that building materials with a low heat tolerance which may degrade at lower temperatures are protected to prevent degradation. Examples of low heat tolerance materials include vinyl siding, fabrics, some plastics, filmy materials, etc.**

It is beyond the scope of these instructions to consider all conditions that may be encountered. Consult local authorities such as the Fire Marshall, insurance carrier, or safety authorities if you are uncertain as to the safety or applicability of the proposed installation.

**Refer to Table 1 & Figure 1 Next Page for the minimum mounting and clearances to combustibles for Outdoor Patio application.**



### WARNING

**DO NOT INSTALL THIS APPLIANCE IN A RECESS, ALCOVE, OR ENCLOSURE.**

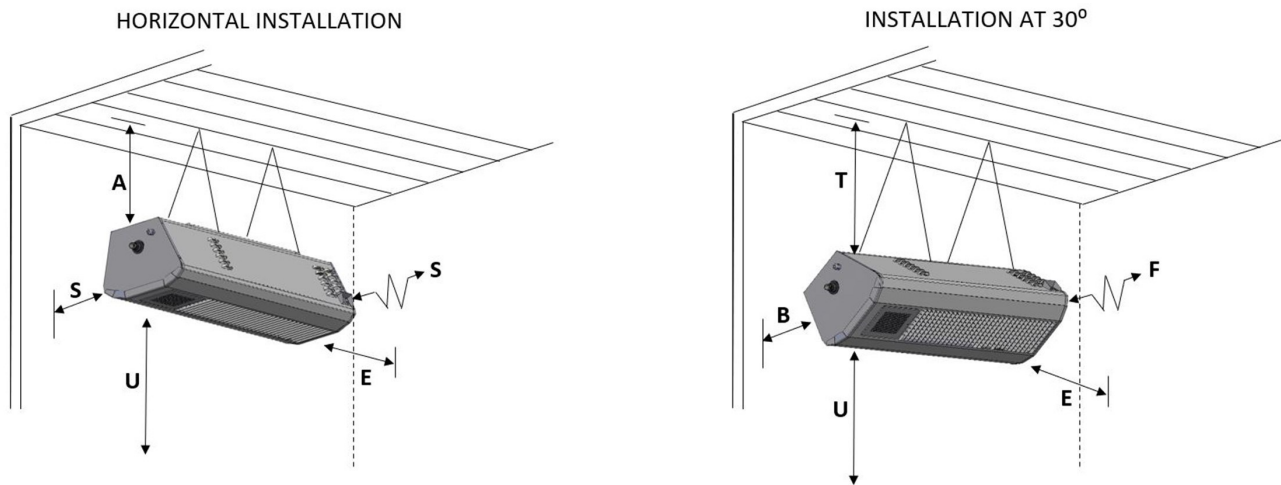
Adequate free space must be provided to allow the products of combustion to escape from the heater to atmosphere when installed outdoors, or to mechanical exhaust withdrawal when installed indoors. Do not allow the products of combustion to accumulate in any space or enclosure.

### **Note: Do not store or place anything directly under heater**

**Ensure mounting height in any location is sufficient to prevent patrons from coming in contact with heater, and clearance to combustibles is maintained.**

**Figure 1: OUTDOOR - MINIMUM CLEARANCES** [Indoor Clearances Page 10]

**NOTE: ANGLE MOUNT IS MAXIMUM 30° TO AVOID DAMAGE**



**Table 1: OUTDOOR - MINIMUM CLEARANCES TO COMBUSTIBLES**

Application	MODEL NO	Horizontal		30° Angle			Under	Ends
		A	S	T	B	F	U	E
OUTDOOR	2312 / IO-212 - NG/LPG	5.5"	7"	9.5"	1"	9.5"	48"	3"
OUTDOOR	2313 / IO-213 - NG/LPG	7.5"	9"	9.5"	1.5"	21"	48"	5"
OUTDOOR	2352 / IO-252 - NG Only	12"	28"	16"	10"	36"	60"	21"

See Table 2 Next Page for "Suggested Mounting Height for Comfort"

**Note: Do not mount less than 8 ft above floor.**  
**Do not store or place anything directly under heater**  
 Ensure mounting height in any location is sufficient to prevent patrons from coming in contact with heater, and clearance to combustibles is maintained.

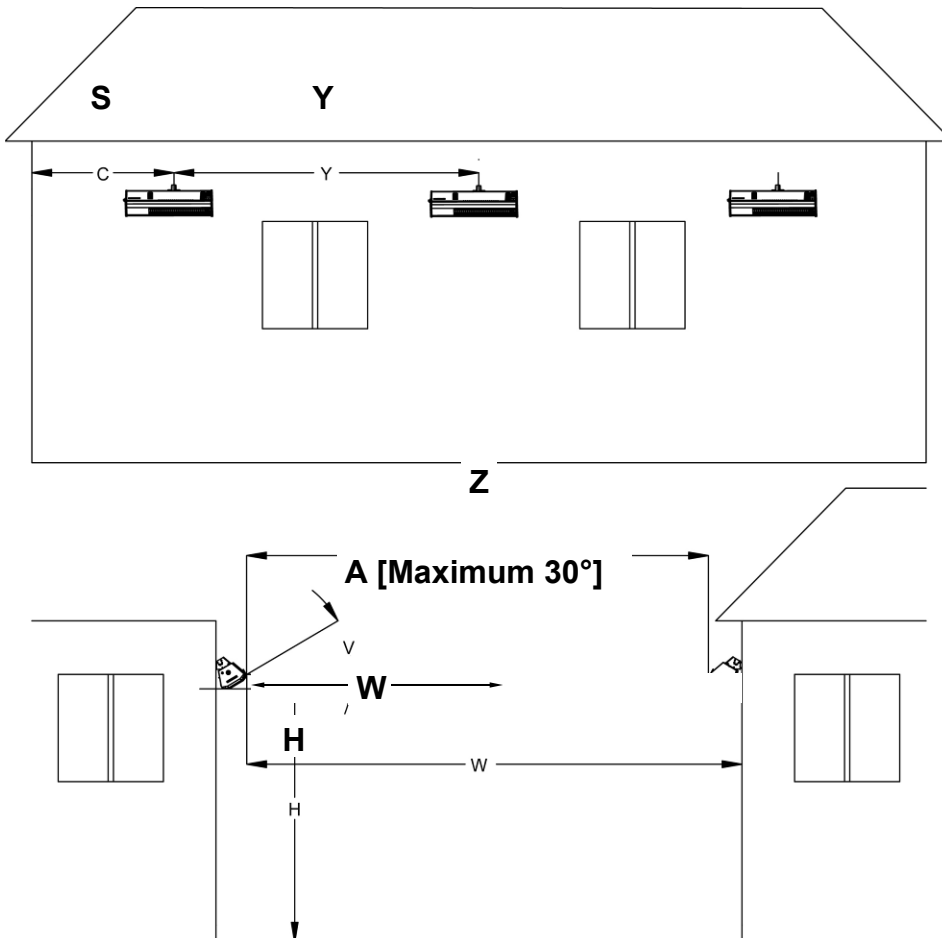
The clearance to combustible material represents the minimum distance that must be maintained between the outer heater surface and a nearby surface. In an OUTDOOR application the stated clearance to combustibles represents a surface temperature of 90F° [50C°] above ambient temperature.

It is the installer's responsibility to ensure that building materials with a low heat tolerance which may degrade at lower temperatures are protected to prevent degradation. Examples of low heat tolerance materials include awnings, vinyl siding, fabrics, some plastics, filmy materials, etc.

**Table 2: SUGGESTED MOUNTING DISTANCES FOR COMFORT**

<b><u>MOUNTING PARAMETERS</u> ***</b>	<b>MODEL 2312 / IO 212 23,000 Btuh</b>		<b>MODEL 2313 / IO 213 35,000 Btuh</b>		<b>MODEL 2352 / IO 252 50,000/35,000 Btuh</b>	
	Horizontal	Max. 30°	Horizontal	Max. 30°	Horizontal	Max. 30°
<b>H - Suggested height above deck/floor</b>	8' to 10'	8' to 10'	8' 6" to 11'	8' 6" to 11'	9' to 12'	9' to 12'
<b>S - Side distance to patio edge</b>	3' 6"	3' 6"	4' 0"	4' 0"	5' 0"	5' 0"
<b>Y - Side distance between heaters</b>	6' 0"	6' 0"	8' 0"	8' 0"	9' 0"	9' 0"
<b>W - Distance effective coverage</b>	6' 0"	7' 0"	7' 0"	8' 0"	8' 6"	9' 6"
<b>Z - Front distance between heaters</b>	12' 0"	14' 0"	14' 0"	16' 0"	17' 0"	19' 0"

**Figure 2: MOUNTING PARAMETER DISTANCES**



\*\*\* Note: Mounting angles and distances are suggested to ensure comfort, and are subject to site and design conditions. If in doubt, please contact your Schwank distributor. Ensure mounting height in any location is sufficient to prevent patio patrons from coming in contact with the heater

---

## WHEN INSTALLED INDOORS FOR COMFORT OR SPACE HEAT

- Also refer to “Outdoor” definition and requirements on page 11
- And refer to Indoor Ventilation Requirements page 19



### WARNING

### Clearance to Combustibles

Location of flammable or explosive objects, liquids or vapors close to the heater may cause fire or explosion and result in property damage, injury or death. Do not use, store or locate flammable or explosive objects, liquids or vapors in proximity of the heater.



**The clearance to combustible material represents the minimum distance that must be maintained between the outer heater surface and a nearby surface. The stated clearance to combustibles represents a surface temperature of 90F° [50C°] above room temperature.**



**It is the installer’s responsibility to ensure that building materials with a low heat tolerance which may degrade at lower temperatures are protected to prevent degradation. Examples of low heat tolerance materials include vinyl siding, fabrics, some plastics, filmy materials, etc.**

In locations used for the storage of combustible materials, signs must be posted to specify the maximum permissible stacking height to maintain the required clearances from the heater to the combustibles. Such signs must either be posted adjacent to the heater thermostats or in the absence of such thermostats in a conspicuous location.

In addition to stored or stationary material, consideration must also be given to moveable objects such as cranes, vehicles, and overhead doors, and structural objects such as electrical and gas lines, electrical fixtures, and sprinkler heads.

Heaters must be located an appropriate distance from sprinkler heads. This distance may be greater than the certified clearance to combustibles. Check the temperature rating of the sprinkler heads and locate heaters at a safe distance - in some instances the sprinkler heads may need to be replaced by higher temperature heads.

It is beyond the scope of these instructions to consider all conditions that may be encountered. Consult local authorities such as the Fire Marshall, insurance carrier, or safety authorities if you are uncertain as to the safety or applicability of the proposed installation.

**Refer to Figure 3 and Table 3 NEXT PAGE for the mounting requirements and certified clearances to combustibles for indoor installation.** Also refer to ventilation requirements for indoor installations on page 19.



### WARNING

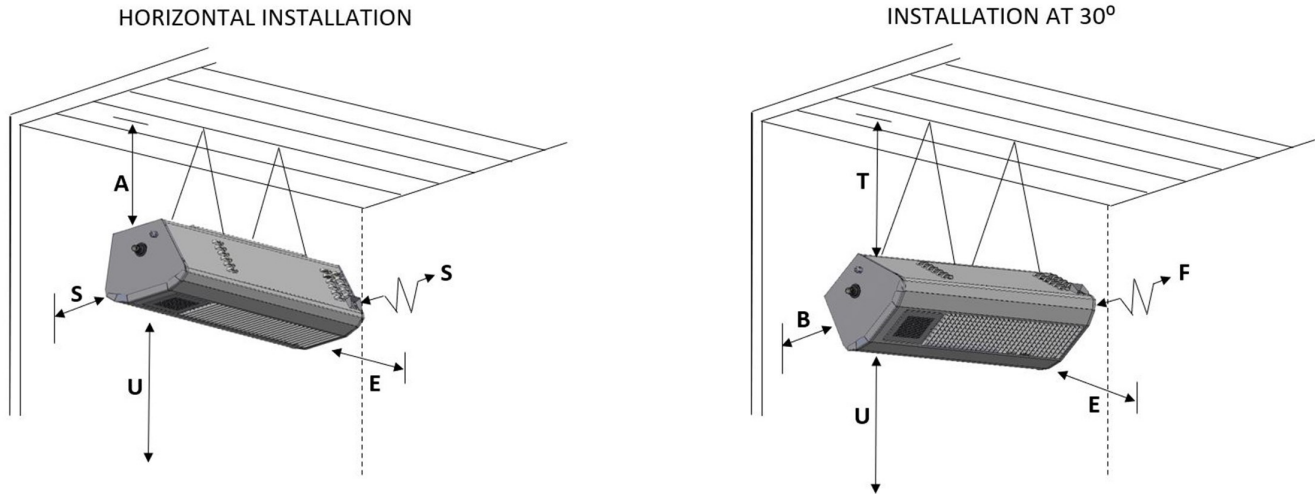
### DO NOT INSTALL THIS APPLIANCE IN A RECESS, ALCOVE, OR ENCLOSURE.

Adequate free space must be provided to allow the products of combustion to escape from the heater to atmosphere when installed outdoors, or to mechanical exhaust withdrawal when installed indoors. Also refer to “Outdoor” and “Indoor” definitions and requirements on page 11.

Do not allow the products of combustion to accumulate in any space or enclosure.

**Figure 3: INDOOR - MOUNTING CLEARANCES** [Outdoor Clearances Page 7]

**NOTE: ANGLE MOUNT IS MAXIMUM 30° TO AVOID DAMAGE**



**Table 3: INDOOR - MINIMUM CLEARANCES TO COMBUSTIBLES**

Application	MODEL NO	Horizontal		30° Angle			Under	Ends
		A	S	T	B	F	U	E
INDOOR	2312 / IO-212 - NG/LPG	8"	10"	12.5"	2.5"	14"	60"	4"
INDOOR	2313 / IO-213 - NG/LPG	10.5"	14.5"	12.5"	2.5"	26"	60"	6"
INDOOR	2352 / IO-252 - NG Only	24"	33"	24"	24"	78"	78"	24"

The clearance to combustible material represents the minimum distance that must be maintained between the outer heater surface and a nearby surface. The stated clearance to combustibles represents a surface temperature of 90F° [50C°] above indoor room temperature.

It is the installer’s responsibility to ensure that building materials with a low heat tolerance which may degrade at lower temperatures are protected to prevent degradation. Examples of low heat tolerance materials include awnings, vinyl siding, fabrics, some plastics, filmy materials, etc.

**Table 4: INDOOR - SUGGESTED MOUNTING HEIGHT FOR COMFORT**

<u>MOUNTING PARAMETERS</u> ***	MODEL 2312 / IO 212 23,000 Btuh		MODEL 2313 / IO 213 35,000 Btuh	
	Mounting angle	Horizontal	MAX. 30°	Horizontal
Suggested height above deck/floor	9' 0"	9' 0"	10' 0"	10' 0"

**1. APPLICATION:** All models are approved to ANSI Z83.26-2014 / CSA 2.37-2014 for heating of outdoor commercial / industrial / residential patios and areas, and are also approved to ANSI Z83.19a-2011 / CSA 2.35a-2011 for heating indoor and outdoor commercial / industrial / non-residential spaces.

It is beyond the scope of these instructions to consider all conditions that may be encountered. Installation in the USA must conform to all local and national code requirements including the current National Fuel Gas code ANSI Z223.1, and the National Electrical Code ANSI/NFPA No 70 [latest edition]. All installations in Canada must conform to local and national code requirements including, CAN/CGA-B149.1 installation code for gas burning appliances and equipment and the Canadian Electrical Code PART 1 CSA C22.1 [latest edition]. In case of discrepancy due to revisions to standards and codes, the latest standards, codes, and installation manual are in effect and take priority.

**DO NOT INSTALL THIS APPLIANCE IN A RECESS, ALCOVE, OR ENCLOSURE.**

Adequate free space must be provided to allow the products of combustion to escape from the heater to atmosphere when installed outdoors, or to mechanical exhaust withdrawal when installed indoors. Also refer to “Outdoor” and “Indoor” definitions and requirements below.

Do not allow the products of combustion to accumulate in any space or enclosure.

**OUTDOOR / PATIO Installation:**

**This heater is certified for use outdoors. Schwank warrants that the heater will operate as designed for patio use in wind conditions up to 10 MPH . Higher wind speeds exceeding 10 MPH can adversely affect heater performance and human comfort conditions on the patio.**

**What is “Outdoor”?:**

An appliance approved for “outdoor use” may be installed with shelter no more inclusive than:

- With walls on all sides, but with no overhead cover, [overhead permanently open]
- **Or** Within a partial enclosure which includes an overhead cover and no more than two side walls. These side walls may be parallel, as in a breezeway, or at right angle to each other. The open sides must be permanently open
- **Or** Within a partial enclosure which includes an overhead cover and three side walls, as long as 30 percent or more of the horizontal periphery of the enclosure is permanently open.

**If an “outdoor” condition is not met, this heater is approved for “indoor use”. Ventilation requirements of local codes apply. See “Indoor Installation” below.**

**INDOOR Installation:**

**This heater is certified for space or spot heating of commercial / industrial non-residential indoor spaces in accordance with ANSI Z83.19 / CSA 2.35.**



**WARNING**

Inadequate venting of a heater may result in asphyxiation, carbon monoxide poisoning, injury or death. Heating system venting must be in accordance with all local, state, provincial, and national codes [ANSI Z223.1/NFPA 54 in USA; B149.1 in Canada].



**INDOOR INSTALLATION IN A STRUCTURE THAT HAS NO INSULATION IN THE ROOF CAN RESULT IN THE FORMATION OF CONDENSATION ON COLD SURFACES.**

## 2. INSTALLATION IN COMMERCIAL AIRCRAFT HANGARS

Luminous [high intensity] radiant tube heaters are suitable for use in aircraft hangars when installed in accordance with the latest edition of the Standard for *Aircraft Hangars*, ANSI/NFPA No 409 in the USA, or the Canadian *Natural Gas and Propane Installation Code*, B149.1.

- A. A minimum clearance of 10 ft [3 m] above either the highest fuel storage compartment or the highest engine enclosure of the highest aircraft which may occupy the hangar. The clearance to the bottom of the heater shall be measured from the upper surface of either the fuel storage compartment or the engine enclosure, whichever is higher from the floor.
- B. A minimum clearance of 8 ft [2.4 m] must be maintained from the bottom of the heater to the floor in other sections of the aircraft hangar, such as offices and shops, which communicate with areas for servicing or storage. Refer to Table 1 for proper mounting clearances to combustibles.
- C. Heaters must be located so as to be protected from damage by aircraft and other objects, such as cranes and movable scaffolding.
- D. Heaters must be located so as to be accessible for servicing and adjustment.

## 3. INSTALLATION IN COMMERCIAL GARAGES AND PARKING STRUCTURES

Luminous [high intensity] radiant heaters are suitable for use in commercial garages when installed in accordance with the latest edition of the Standard for *Parking Structures*, ANSI/NFPA 88A, or the Standard for *Repair Garages*, ANSI/NFPA No. 88B, or the Canadian *Natural Gas and Propane Installation Code*, B149.1.



### **WARNING**

An overhead heater shall be located to maintain the minimum distance to combustibles, as shown on the heater rating plate, from the heater to any vehicles parked below the heater.

Overhead heaters shall be installed at least 8 ft [2.4 m] above the floor.

## 4. INSTALLATIONS OTHER THAN SPACE HEATING

Use for process or other applications that are not space heating will void the C.S.A. certification and product warranty. Process application requires field inspection and/or certification by local authorities having jurisdiction. Process application design should be provided by local experienced process design experts.

## 5. PRE INSTALLATION SURVEY

It is recommended that a full heating design including heat loss calculation be conducted on the structure or area to be heated. Heater sizing and placement must consider available mounting height, sources of greatest heat loss, and obstructions on the site. The certified clearances to combustibles with respect to stored material, moveable objects [cranes, vehicles, lifts,

overhead doors, etc], structural components, and sprinkler system heads. Consideration must also be given to ventilation fan placement [outdoor heaters do not require ventilation]. Carefully survey the area to be heated, and for best results place heaters in the coldest area[s] and at sufficient spacing to provide uniform radiant heat coverage.

Installation must conform with all local, state, provincial and national code requirements including the current latest edition ANSI Z223.1 [NFPA 54] in the U.S.A. and B149.1 installation code in Canada, for gas burning appliances and equipment. The latest edition Electrical Code ANSI/NFPA N0 70 in the U.S.A. and PART 1 CSA C22.1 in Canada must also be observed.

The heating system must have gas piping of the correct diameter, length, and arrangement to provide for and satisfy the total system input. A layout drawing is necessary to calculate properly sized gas supply piping.

## **6. INSTALLATION REQUIREMENTS**

### **6.1 MOUNTING CLEARANCES**

Series 2300 / IO 210 Heaters must be mounted with minimum clearances to combustible materials. Refer to the introductory section "Clearance to Combustibles" pages 6 to 10 and to Table 1 and Figure 1 page 7 [Outdoor] or Table 3 and Figure 3 page 10 [Indoor].

**THIS HEATER HAS HOT SURFACES:** Minimum mounting height is to be no less than 87" above the floor / deck. Do not locate heater where patrons can come into contact with heater. Do not store or place items directly underneath heater. Maintain clearance to combustibles.

The heater must be located with respect to building construction and equipment so as to provide sufficient clearance and accessibility for servicing of burner and ignition control and cleaning . Provide adequate clearance around air openings into the combustion chamber.

### **6.2 HEATER MOUNTING**

**This heater must be rigidly mounted to prevent movement from wind force.**

**Refer to Table 2 and Figure 2.** Series 2300 / IO 210 Heaters are approved for both horizontal and 30° angle mounting on the short axis. Schwank specifies a **MAXIMUM 30° mounting angle** - if the short axis is rotated to an angle exceeding 30°, damage to the heater or unsafe operation can result, and will void warranty.

**IMPORTANT:** For either horizontal or up to 30° angle mounting, the long axis of the heater must be level. Use only non-combustible mounting hardware. Figures 6 & 7 on Page 21 illustrate typical suspension hardware that may be used, and provided by Schwank/Infrasave as an optional component.

## 7. GAS SUPPLY PIPING

- All piping must be installed according to applicable local and national codes
- A listed flexible connector [field supplied] must be installed between the heater and gas supply piping. For outdoor installation the connector must be in compliance with ANSI Z21.75 / CSA 6.27. An optional 3/8" x 24" black finish flexible gas connector [part number JL-0771-OD - approved Indoor/Outdoor] is available from Schwank / InfraSave.
- A drip-pocket must be provided in the gas piping at the inlet connection
- Provide a 1/8" NPT plugged tapping, accessible for test gage connection, immediately upstream of the gas supply connection to the heater.
- On propane-fired units, a main line filter is recommended [field supplied]
  - Piping joint compounds must be resistant to the action of liquefied petroleum gases
- All piping joints must be tested for leaks with a soap and water solution.

**CAUTION:** DO NOT INSTALL ANY GAS PIPING IN HEAT ZONES

### 7.1 GAS PRESSURE

The maximum supply pressure must be limited to 14" w.c. [0.5 psi]. If the line pressure is above 14" w.c., then a separate pressure reducing regulator must be installed. The minimum pressure at the inlet to the heater regulator must be equal to or greater than 6.0" w.c. for natural gas and 11.0" w.c. for propane gas.

Proper manifold pressure must be established during commissioning, and will be maintained when the main burner is operating under the following supply pressure:

MODELS	GAS TYPE	LINE PRESSURE "w.c.		MANIFOLD PRESSURE "w.c.
		MINIMUM	MAXIMUM	AT GAS VALVE TEST PORT
<b>2312, 2313 / IO-212, IO-213</b>	NATURAL GAS	6.0	14.0	5.0
	PROPANE GAS	11.0	14.0	10.0
<b>2352 / IO-252 [2-Stage]</b>	NATURAL GAS [ONLY]	6.0	14.0	5.0 High; 3.0 Low

Natural Gas: Orifice sized for 1000 BTU/CU.FT.

Propane Gas: Orifice sized for 2500 BTU/CU.FT.

## 8. BASIC ELECTRICAL REQUIREMENTS - see also Section 16 page 25

All electrical installations must meet local codes and the latest edition ANSI/NFPA N0 70 in the U.S.A. and Electrical Code PART 1 CSA C22.1 in Canada .

### **TRANSFORMER SPECIFICATIONS** [field supplied]

**Single heater** requires 24 Volt, 60 Hz electrical transformer sized at 40 VA.

**Multiple heaters** in a zone are powered by a single transformer [field supplied]. The proper transformer is 24 Volt AC, 60 Hz, sized at 40VA for the first heater plus 20VA for each additional heater in the zone - round up the calculated value to the next higher available sized transformer. For example, four heaters in a zone require a transformer of : 1 x 40VA + 3 x 20 VA = 100 VA . It is not recommended to install more than 12 heaters per zone.

PROPER WIRING POLARITY MUST BE MAINTAINED, particularly when grouping the heaters in a zone. Total wiring distances of up to 200' must use minimum 16 gauge electrical wire, and wiring distances of over 200' must use minimum 14 gauge electrical wire. The heater must be electrically grounded in accordance with local and national electrical codes. Malfunction of the heating system will result if the voltage varies by more than  $\pm 10\%$  .

The heater can be controlled by a line voltage thermostat, a 24 volt thermostat or "off-on" switch. Total load of all heaters must be considered in determining the required contact rating of the controlling thermostat or switch.

## 9. INSTALLATION PROCEDURES

- a] Properly install gas line to all local codes
- b) Mount heaters using non-combustible mounting hardware
- c) Observe all minimum clearances as indicated: OUTDOOR in Table 1 and Figure 1, page 7; INDOOR in Table 3 and Figure 3, page 10.
- d) Suggested mounting distances for comfort in Table 2 and Figure 2 are guidelines based on experience. Site conditions can allow for some deviation from these distances.

**WARNING: This heater must be rigidly mounted to prevent movement from wind force.**

When using Mounting Brackets, ensure that anchoring to the structure is of sufficient strength, integrity and workmanship, to support the weight of the heater and any other loads such as snow and wind force.

- e) Connect heater to the main gas line. An approved 1/2" flexible connector [field supplied - available as an option from the manufacturer] must be used to absorb heater and gas line expansion and any vibration - check local code requirements.
- f) Check gas line for leaks by using soap test or gas meter test. Ensure gas pressure meets the requirements outlined in Section 7.1 [above].

**WARNING:** *When testing the main gas line pressure up to 0.5 psig, ensure that the isolation valve and combination gas valve are "OFF", otherwise damage to the combination gas valve will result. When testing main gas line in excess of 0.5 psig the appliance and shut off valve must be disconnected or isolated from the gas supply piping system during any such pressure testing. Gas supply to the heater must be regulated to be maximum 0.5 psig [14" w.c.] and minimum values listed in Table 3 above in Section 7.1*

- g) All wiring must comply to local and national codes. The heater requires 24Vac power supply. The heater system zone requires a field supplied 120/24Vac transformer rated at 40VA for the first heater *plus* 20VA for each additional heater in the zone. Ensure proper electrical rating in the system by checking voltage at ignition module terminals. To avoid system malfunction, the voltage range must be within 10% of required 24Vac [21.6 Volts to 26.4 Volts], and correct polarity must be maintained throughout the system.
- h) Test-fire the heating system by following the lighting instructions listed below and on the heater label.

## 10. LIGHTING INSTRUCTIONS

1. Ensure the correct voltage is supplied, gas supply lines have been properly purged, and gas valve is switched to the ON position.
2. Turn on power to heater, set thermostat [if applicable] to above ambient temperature, the heater will light.
3. If heater does not light: Turn off power to heater, turn gas valve to OFF position.
4. Wait for five minutes and repeat steps above. If heater does not light after three attempts, call a qualified service technician.

### 10.1 SHUT DOWN INSTRUCTIONS

- a) For temporary shutdown, turn off the electrical supply circuit.
- b) For complete shutdown, turn off the electrical circuit and turn gas control knob to the "OFF" position.

## 11. HEATER FINISH AND APPEARANCE

All models are constructed with a marine grade stainless steel enclosure cabinet, with optional finish of stainless steel, or high temperature black coating.

**Stainless Steel Enclosure Heater:** ALL stainless steel heaters will discolor or stain to some extent due to the impact of heat. This is a normal occurrence and does not effect heater performance or the warranty of components.

**High Temperature Coating Finish Heater:** Exterior heater surfaces, including any stainless steel components, are coated with a black high emissive coating that helps preserve the aesthetic appearance of the heater and improves the radiant heat output.

Handle the heater with care during installation and service to avoid scratching or damaging the finish.

With extended use, the finish coat will discolor and deteriorate to some extent due to the impact of heat, the deposit of ambient air born particles, and environmental factors.

These are normal occurrences caused by heat, products of combustion, and the environment, and in no way affect the operation / performance of the heater or the manufacturer's warranty.

### OCCASIONAL PAINT FINISH MAINTENANCE:

Wear protective gloves, eyewear, and breathing mask. Ensure that power to the heater is disconnected prior to maintenance and the application of any finish coating. Use a fine steel wool to remove blemishes or unsightly deposit, and smooth the outer surface. The heater finish coat can be touched up using a high temperature coating such as ThurmaloX Stove Paint - Flat Black-1200°F [650°C] or similar high temperature stove paint that is compatible with the original finish. **No other coating or non-high-temperature paint finish may be applied to the heater – use of an incompatible finish coating will create a hazardous condition such as fire or noxious fumes, damage the heater, and void the warranty.**

Apply the touch up finish with the heater in its operating orientation [facing down]. Ensure that overspray does not reach or effect the egg crate grilles and the burner tile surface - mask the heater grilles during any re-finishing. Remove the masking immediately after re-finish and prior to operation of the heater.

## 12. **SERVICING GUIDE** [Also refer to Troubleshooting Guide on page 29]

Servicing of heater is essential for continued efficient operation. Servicing should be carried out annually by a qualified gas service technician as follows:

- Clean the ceramic tiles with compressed air. Avoid directing air stream at gasket material between tile and heater body. The air pressure **must be lower than 20 psig.**
- Clean venturi tube with compressed air. The air pressure **must be lower than 20 psig.**
- Ensure gas orifice is clean and the heater cabinet is free of any debris

### **Indication of back firing:**

- *Loud ignition noise, followed by distinct hissing sound.*
- *Little or no visible burning on the ceramic tile surface.*
- *Combustion is taking place inside the burner body.*

**WARNING:** *If heater backfires during operation, it **must** be turned off **immediately.***

### **Cause & remedy of back firing:**

- *Improper gas pressure entering the venturi tube: check pressure.*
- *Breakage of a ceramic tile and or gasketing: - replace damaged part.*
- *Faulty sealing of the ceramic tile to the burner body, caused by breakdown of gasket material: contact your local distributor or contractor.*

## **HEATER SERVICING POSITION:**

WHEN USING WALL MOUNT BRACKET JP-2300-MB [see Figure 4 next page], the heater may need to be rotated 'up' so that access is provided to the service access door at the rear side of the heater that is against the wall.

1. To allow rotation of the heater, slacken the upper bolt fastening the heater bracket to the wall mounting bracket .
2. Remove the lower bolt securing the two brackets and rotate the heater up to the service position.
3. Insert the bolt in the upper bracket hole to hold the heater for servicing, and apply locking nut to bolt for extra safety. Heater panel can now be accessed and serviced safely.
4. **NOTE: Do not start up the heater when in this upper service position as the gas valve is in a compromised position. Before starting the heater, ALWAYS restore the heater bracket back to its original plane and correct support position.**
5. To restore the heater to the operating position, lift and support the weight of the heater and remove nut and bolt from upper hole.
6. Slowly rotate the heater back down to the correct operating position.
7. Insert and fasten the bolt in the bottom hole, and secure with the nut.
8. At completion of service, ensure that both bracket support bolts are tightened securely.

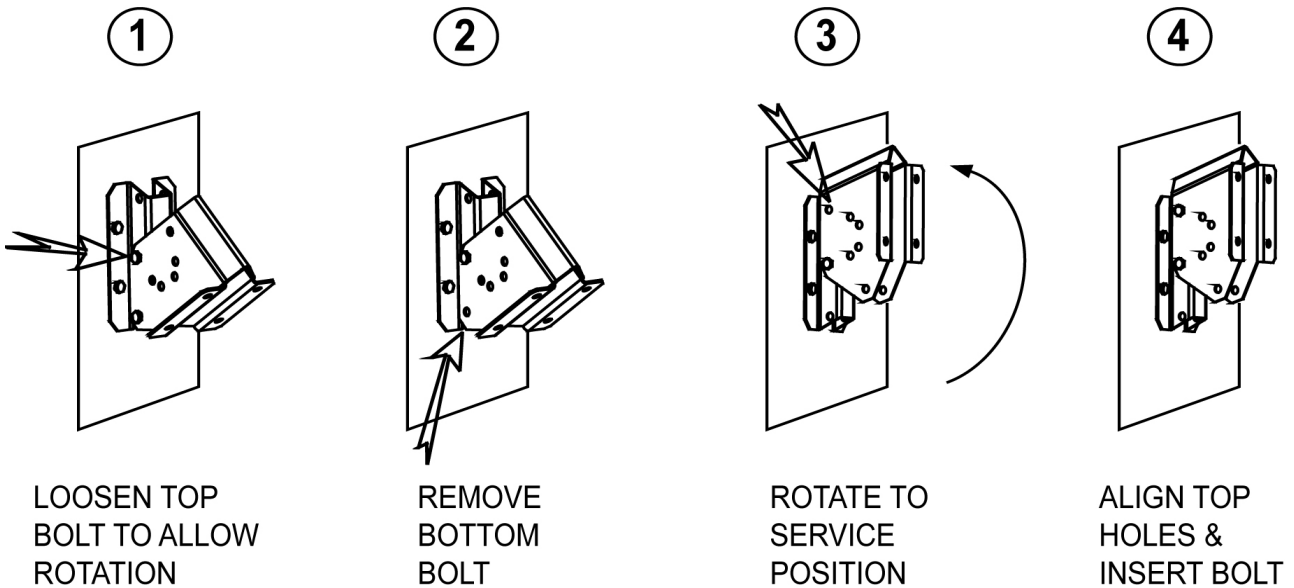
**Figure 4: HEATER SERVICE POSITION WITH WALL MOUNT BRACKET**

**FOR SERVICING HEATER:** [To simplify illustration the heater is not shown]

IT IS NOT NECESSARY TO REMOVE HEATER FROM SUPPORT BRACKET  
DRAWINGS SHOW JUST THE BRACKET FOR BETTER VIEW

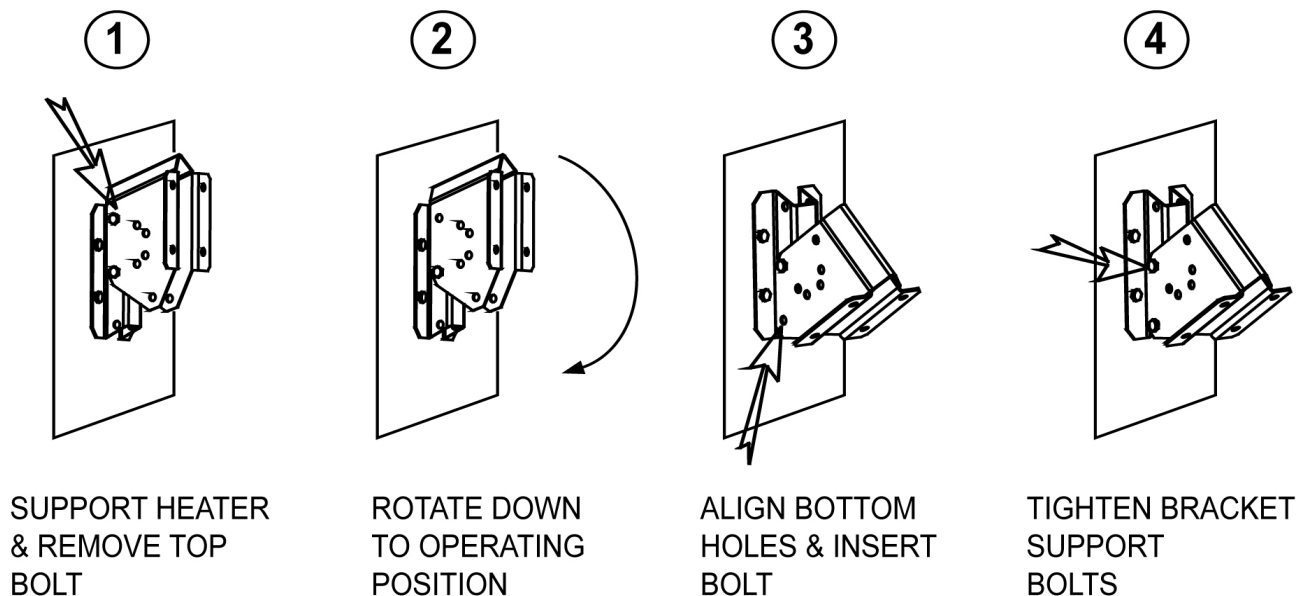
### **ROTATE TO SERVICE POSITION**

---



### **LOWER TO OPERATING POSITION**

---



## 13. VENTILATION REQUIREMENTS FOR INDOOR APPLICATION



### WARNING



Inadequate venting of a heater may result in asphyxiation, carbon monoxide poisoning, injury or death. Heating system venting must be in accordance with all local, state, provincial, and national codes [ANSI Z223.1/ NFPA 54 in USA; B149.1 in Canada].

This heater is approved for unvented [indirect venting] application. Ensure that there is adequate ventilation to supply combustion air and to dilute the products of combustion in accordance with all local, state, provincial, and national codes. A balanced exhaust / inlet air system is required to ensure that a negative air condition is not created. See below for a summary of exhaust capacity requirements by the national codes in the U.S.A. and Canada.

**Air Supply:** A “loose” building may not require any additional air supply if infiltration rates are sufficient to offset exhaust volume. However, for “tighter” buildings, or if air movement is stagnant in an area, air can typically be supplied via inlet[s] with an area of 1 sq. in. per 1,000 Btuh input [22 sq cm per kW]. Locate air inlet[s] up at the level of the heaters to avoid cold drafts at work level, and effectively supply combustion and dilution air to the heaters and balance the system.

**Heater Zoning:** Exhausters are sized according to the input requirements of each controlled zone of heaters. Multiple smaller zones are usually more effective in both comfort and ventilation control than one large zone. Maximum zone size is limited by the total input that can be handled by the capacity of an exhauster, and by the proximity of the exhauster to heaters in the zone.

**Exhauster Location & Proximity:** Exhaust must be located as high as practicable in the structure above the level of the heater[s] to effectively dilute and remove the warm [rising] products of combustion. The exhauster should be as centrally located as practicable in the zone of heaters. Schwank recommends a maximum 6:1 ratio of the horizontal distance between the exhauster and the furthest heater in a zone, to the height the heaters are mounted above the floor. For example, if heaters are mounted 20 ft above the floor, then the exhaust fan should be located no more than 120 ft from the furthest heater in the zone. Sufficient air supply must be provided.

### Exhauster Capacity:

**USA:** Natural or mechanical means shall be provided to supply and exhaust at least  $4\text{ft}^3/\text{min}/1000\text{Btuh}$  [ $0.38\text{m}^3/\text{min}/\text{kW}$  Natural Gas input of installed heaters [ $4.5\text{ft}^3/\text{min}/1000\text{Btuh}$  [ $0.43\text{m}^3/\text{min}/\text{kW}$  Propane input]]. Some local codes may require an interlock to a dedicated exhaust fan. Consult your local code and ANSI Z223.1 latest edition for all venting requirements and practices.

**Canada:** It is required that the heater[s] be electrically interlocked to dedicated exhaust fan[s] by means of an Air Proving Switch. Exhaust fan[s] must be sized to create 300 cfm [ $8.5\text{ cu m}/\text{min}$ ] exhaust for every 100,000 Btuh [30 kW] or any portion thereof of total input of installed equipment. Provide combustion and ventilation air supply compatible with exhaust volume. Consult the latest edition of CSA.B149.1 Section 7.22.

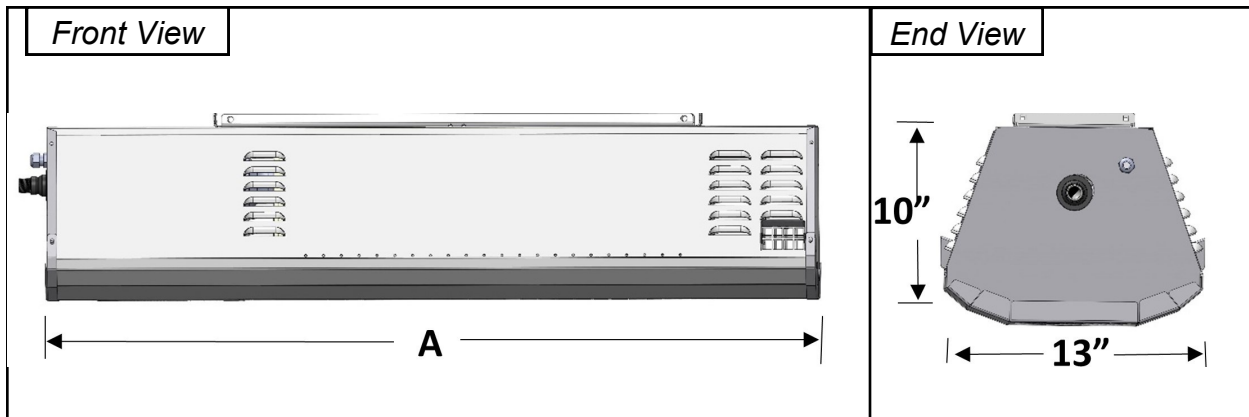
## 14. HEATER DIMENSIONS & CONFIGURATIONS

**Table 5: CAPACITIES & CONFIGURATIONS**

MODEL	Voltage VAC	Current amps	Btu/hr input	Total Weight [lbs].	Length < A >
2312 / IO 212 -NG	24	40 VA*	23,000	32	30 1/2"
2312 / IO 212 -LP			23,000	32	30 1/2"
2313 / IO 213 -NG			35,000	44	43 1/2"
2313 / IO 213 -LP			35,000	44	43 1/2"
2352 / IO 252 -NG			50,000/35,000	49	48 1/4"

\* For a multiple heater installation, the first heater is sized at 40VA and each consecutive heater is sized at 20VA. The sum total will be the required Transformer size. If total VA exceeds one transformer size select the next higher VA rated transformer.

**Figure 5: DIMENSIONS**



## 15. MOUNTING KIT OPTIONS [NOTE: For unusual mounting application contact manufacturer.]

Optional mounting kits available:

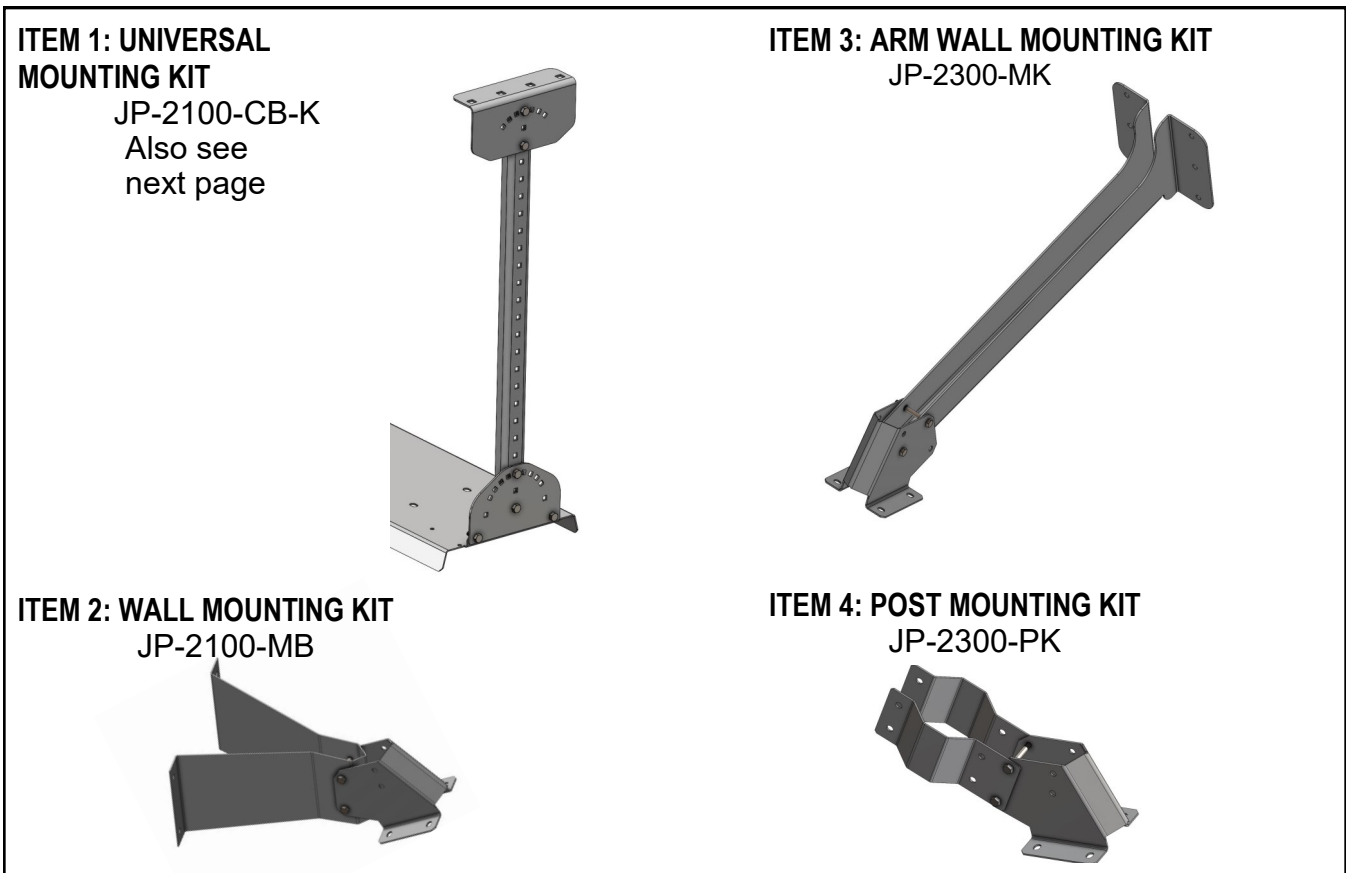
ITEM NO	PART NUMBER	DESCRIPTION
1	JP-2100-CB-K	UNIVERSAL MOUNTING KIT
2	JP-2100-MB	WALL MOUNTING KIT
3	JP-2300-MK	ARM WALL MOUNTING KIT
4	JP-2300-PK	POST MOUNTING KIT

**WARNING: This heater must be rigidly mounted to prevent movement from wind force.**

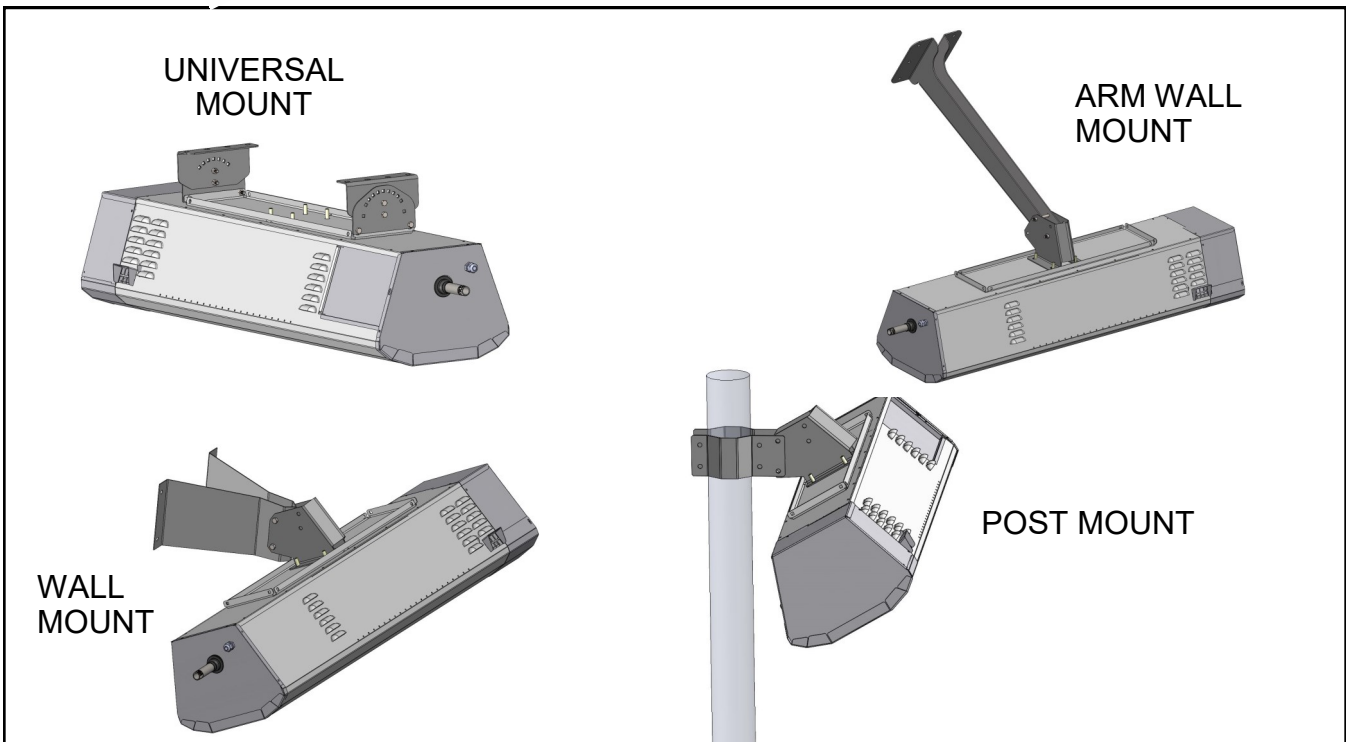
Mounting Brackets: Ensure that anchoring to the structure is of sufficient strength, integrity and workmanship, to adequately support the weight of the heater and any other potential loads such as snow build up, and wind force.

**Figure 6: MOUNTING KIT OPTIONS**

**NOTE: MOUNT HEATER AT MAXIMUM 30° ANGLE TO AVOID DAMAGE**



**Figure 5: MOUNTING OPTIONS**

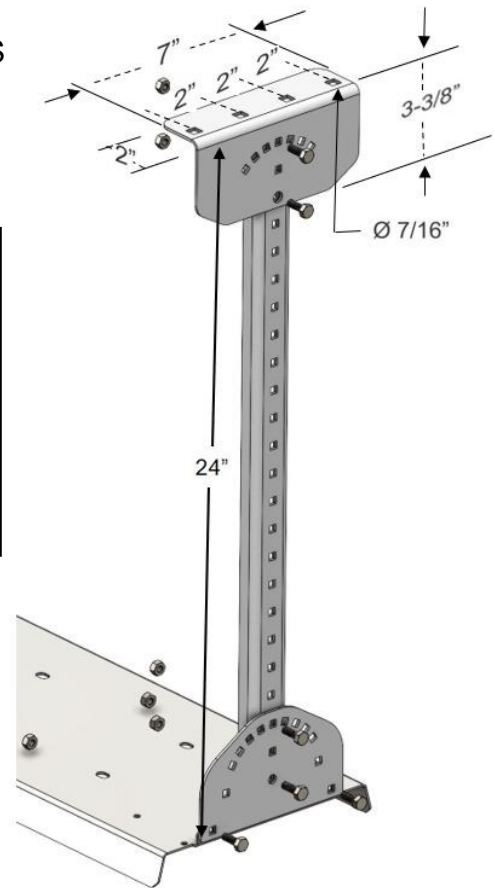


## JP-2100-CB-K: UNIVERSAL MOUNTING KIT for Patio Heaters

### Component Quantities and Material Specifications each Kit:

- 2 x Ceiling/Wall Bracket - 12 ga. [0.102"] 316 S/S
- 2 x 24" [610 MM] Channel Leg - 12 ga. [0.102"] 316 S/S
- 2 x Heater Attachment Bracket - 12 ga. [0.102"] 316 S/S
- 12 x 1/4" x 3/4" Stainless Steel Bolts
- 12 x 1/4" Stainless Steel KEP Nuts  
[lock washer attached]

**Figure 8:** UNIVERSAL MOUNTING KIT



**Note:** It is the installer's responsibility to ensure:

- Adequate mounting strength and integrity to the structure using field supplied 3/8" lag screws or bolts
- Maintain required clearances to combustibles from heater
- Refer to manual: heater weights; required clearances

### Assembly: [Fig 8]

The 24" Channel Leg can be cut to a shorter length

- Ensure required clearances to combustibles from heater are maintained

Fasten the Ceiling/Wall Bracket and Heater Attachment Bracket to the Channel Leg using two supplied 1/4" bolts at each connection as illustrated.

The arc of holes in the Ceiling/Wall Bracket allows angling of the Channel Leg from the bracket up to 45°, and/or mounting the bracket to a sloped ceiling.

The arc of holes in the Heater Attachment Bracket allows angle mount of the heater.

- **NOTE: Maximum allowed heater angle is 30°**

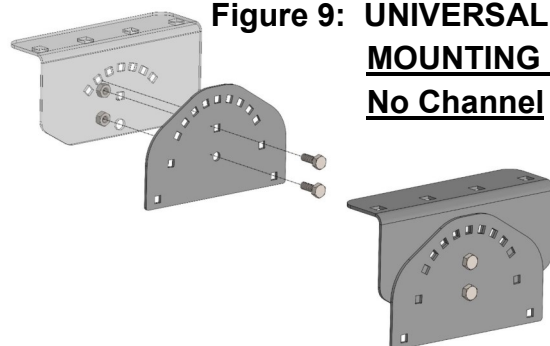
Fasten an assembled mounting bracket to each end of the Heater Support Bracket [supplied on heater] using two 1/4" bolts supplied.

### Note: Only for 2300 Series & IO-200 Series

The Ceiling/Wall and Heater Attachment Brackets can be fitted directly to one another [Fig 9] without the Channel Leg, and yet achieve minimum clearance of 5-1/2" above for 2300 & IO-200 Series.

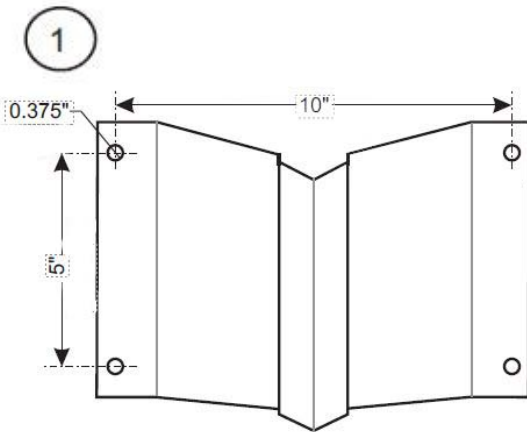
Discard the Channel Legs.

**Figure 9:** UNIVERSAL MOUNTING KIT - No Channel

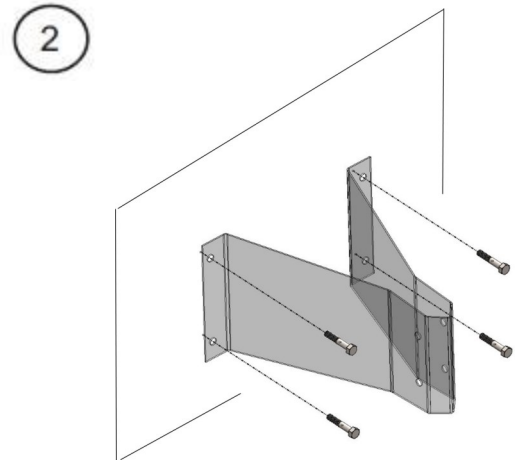


**Figure 10: HEATER INSTALLATION: JP-2100-MB : WALL MOUNTING KIT**

**NOTE: MOUNT AT MAXIMUM 30° ANGLE TO AVOID DAMAGING HEATER**

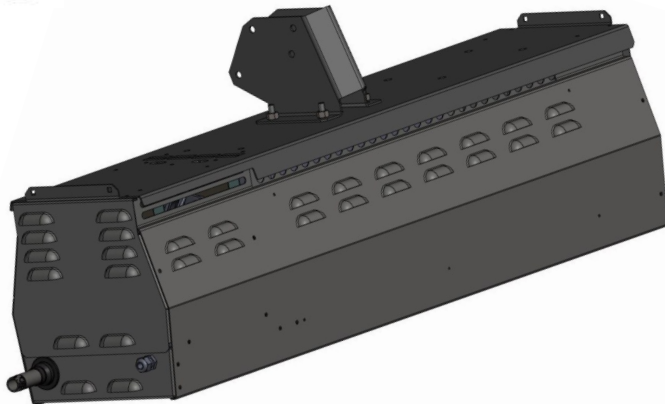


USE BRACKET AS TEMPLATE FOR HOLES/BOLTS TO THE STRUCTURE. FASTEN TO STRUCTURAL MEMBER[S] OR DEVISE STRUCTURAL SUPPORT TO CARRY WEIGHT OF HEATER AND WIND/ SNOW LOADS

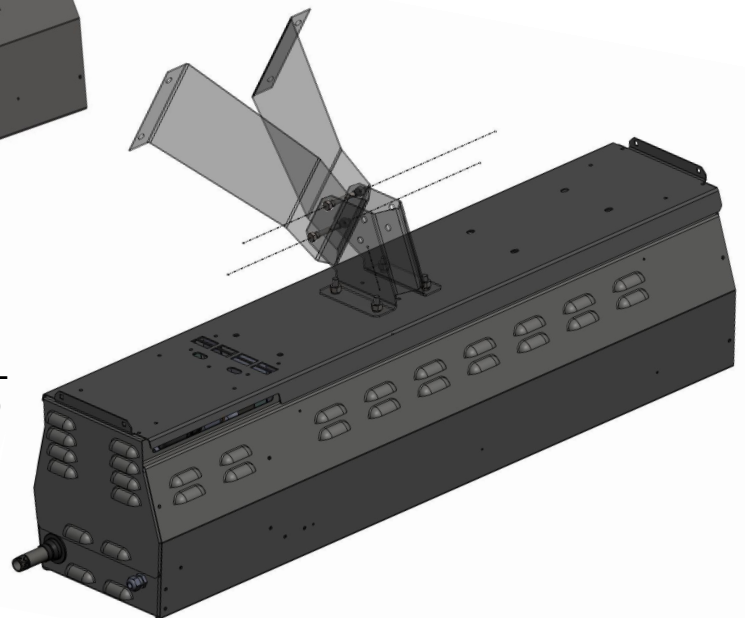


FASTEN WALL BRACKET TO STRUCTURE USING FIELD SUPPLIED FASTENING HARDWARE. ENSURE SUFFICIENT STRENGTH AND INTEGRITY TO CARRY WEIGHT OF HEATER AND WIND/ SNOW LOADS

3 FASTEN HEATER BRACKET TO STUDS ON TOP OF HEATER



4 INSTALL HEATER BRACKET ON TO WALL BRACKET USING BOLTS SUPPLIED [INSERT TOP BOLT FIRST TO CARRY WEIGHT OF HEATER]

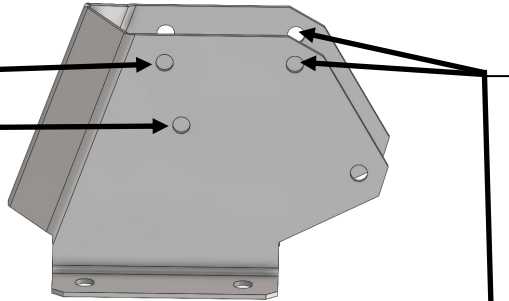


## JP-2300-MK : ARM WALL MOUNTING KIT

**NOTE: MOUNT HEATER AT MAXIMUM 30° ANGLE**

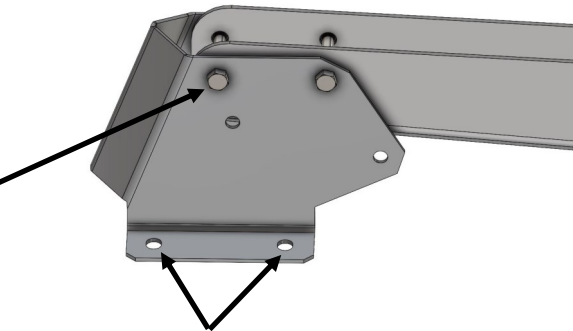
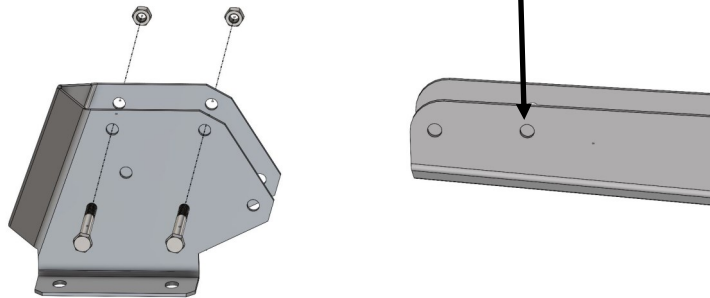
Using pairs of holes in the **heater bracket** allows heater orientation:

- Horizontal
- Angled at 30°  
[MAXIMUM angle mount]



Assemble Mounting Bracket to Mounting Arm using bolts and nuts supplied:

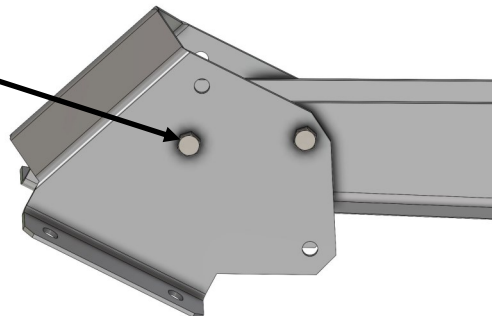
- Align the anchor holes in the heater bracket and the mounting arm, and insert a bolt
- Finger tighten nut on to bolt to allow rotation of the heater bracket
- Align the desired mounting angle holes in the heater bracket to the outermost holes in the mounting arm
- Insert second bolt and finger tighten ONLY nut to bolt
- Horizontal mount
- 30° Angle mount



Studs at top of heater to mounting bracket

### IMPORTANT

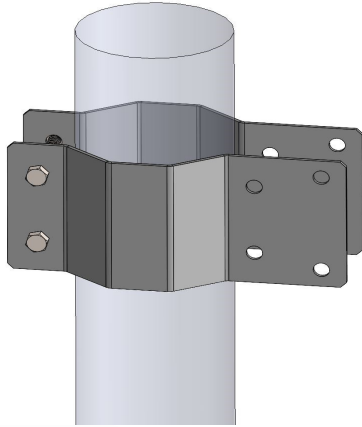
- **Install heater to mounting bracket [4 studs / nuts] BEFORE** tightening nuts on bolts to mounting arm with wrench



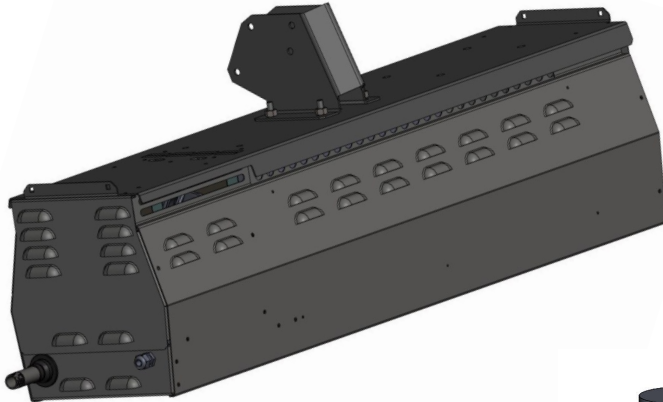
## JP-2300-PK POST MOUNTING KIT

USE CARE NOT TO DAMAGE OR SCRATCH HEATER DURING INSTALLATION

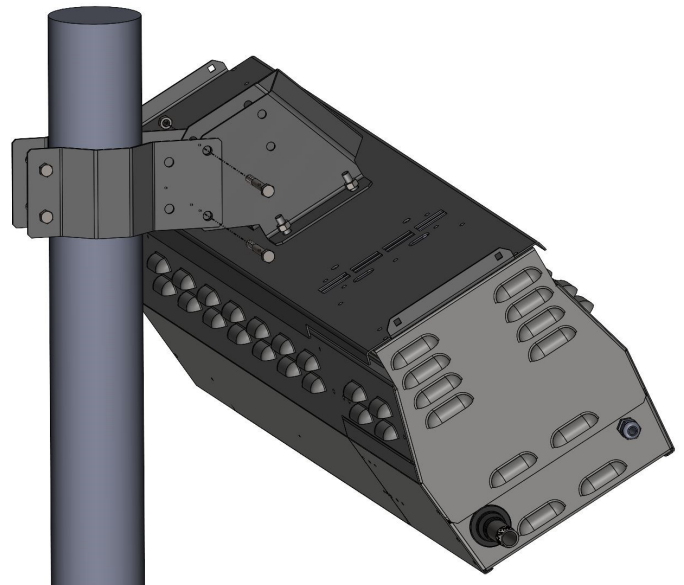
- 1 FASTEN THE TWO POLE CLAMPS TO STRUCTURE USING FIELD SUPPLIED FASTENING HARDWARE. ENSURE SUFFICIENT STRENGTH AND INTEGRITY TO CARRY WEIGHT OF HEATER AND WIND/SNOW LOADS



- 2 FASTEN HEATER BRACKET TO STUDS ON TOP OF HEATER



- 3 INSTALL THE TWO POLE CLAMPS ON TO WALL BRACKET USING BOLTS SUPPLIED [INSERT TOP BOLT FIRST TO CARRY WEIGHT OF HEATER]



## 16. ELECTRICAL REQUIREMENTS AND THERMOSTAT CONTROL

All electrical installations must meet local and the latest edition Electrical Code PART 1 CSA C22.1 in Canada and ANSI/NFPA N0 70 in the U.S.A.. Single heater requires 24 Volt, 60 Hz electrical transformer sized at 40VA. If multiple heaters are connected to a single transformer, the proper transformer is 24 Volt, 60 Hz, sized at 40VA for the first heater, and 20VA each for all subsequent additional heaters. For example, four heaters wired together [parallel], require a transformer of 100 VA. It is recommended to install at most 2 heaters per zone for best comfort control and economy of operation. PROPER WIRING POLARITY MUST BE MAINTAINED, particularly when grouping the heaters in a zone.

Total wiring distances of up to 200' must use minimum 16 gauge electrical wire, and wiring distances of over 200' must use minimum 14 gauge electrical wire. The heater must be electrically grounded in accordance with the local electrical code. Malfunction of the heating system will result if the voltage varies by more than  $\pm 10\%$ .

The heater can be controlled by a line moisture proof thermostat "off-on" switch, or Remote Control. Total load of all heaters must be considered in determining the required contact rating of the controlling thermostat or switch.

### 16.1 CONTROL OPTIONS

Patio Heaters can be operated using Remote Control Option: [Except 2352 / IO-252 2-stage]

- JP-1236-RK Remote Receiver Kit [field installs in heater]
- JP-1236-HS Remote Handset
- Refer to the manual accompanying the Remote Receiver Kit for installation.

Two-Stage Model 2352 / IO-252 requires one of the Illuminated Switch Gang 2-Stage Control options. These switches have [and must have] a special "Off", "On", "On" sequence that powers the heater and two-stage gas valve. Each switch is illuminated when in the "On" position for easy recognition of heater status.

<u>24VAC SWITCH</u>	<u>CONTROL</u>	<u>PART #</u>
Single Switch Gang	1 Zone of 1 To 4 Heaters	JM-0201-TS
Double Switch Gang	2 Zones: 2 To 8 Heaters	JM-0202-TS
Triple Switch Gang	3 Zones: 3 To 12 Heaters	JM-0203-TS



**JM-0201-TS**



**JM-0202-TS**



**JM-0203-TS**

## 17. SEQUENCE OF OPERATION FOR FENWAL 35-60 DSI CONTROL

### Start up - Heat Mode:

On a call for heat the Fenwal 35-60 control will reset, perform a self check routine, flash the diagnostic LED for up to four seconds. The gas valve and spark are energized commencing the trial for ignition period. When flame is detected during the trial for ignition, spark is shutoff immediately and the gas valve remains energized. The thermostat and main burner flame are constantly monitored to assure the system continues to operate properly. When the thermostat is satisfied and the demand for heat ends, the gas valve is de-energized.

### Flame Failure - Multi Trial Model:

Should the main burner fail to light, or the flame is not detected during the first trial for ignition period, the gas valve is de-energized and the control goes through an interpurge delay before another ignition attempt. The control will attempt two additional ignition trials before going into lockout and the valve relay is de-energized.

Recovery from lockout requires a manual reset by either resetting the thermostat or removing 24 volts for a period of 5 seconds. If the thermostat is still calling for heat after one hour the control will automatically reset and attempt to ignite the burner again.

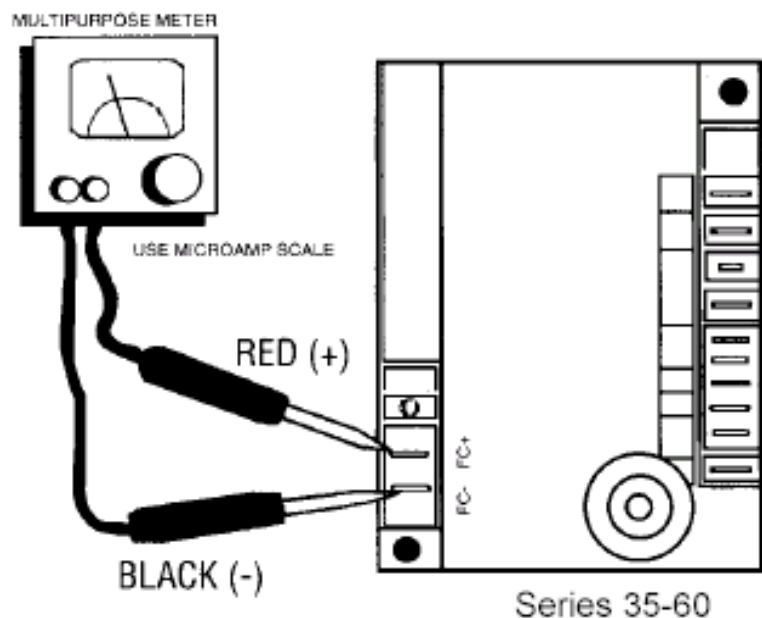
### Flame Failure - Re-Ignition:

If the established flame signal is lost while the burner is operating, the control will respond within 0.8 seconds. The HV spark will be energized for a trial ignition period in an attempt to relight the burner.

If the burner does not light the control will make two more attempts to relight the burner before de-energizing the gas valve. If the burner does not relight, the control will go into lockout as noted above in "Failure to light". If flame is re-established, normal operation resumes. Multi-try models will allow three trials for ignition including interpurge delay between trials.

**Flame current** is the current which passes through the flame from the sensor to ground. The minimum flame current necessary to keep the Fenwal 35-60 system from lockout is 0.7 microamps [ $\mu A$ ]. To measure the flame current, connect analog DC microammeter to the FC-FC+ terminals.

Meter should read 0.7  $\mu A$  or higher. If the meter reads below "0" on scale, meter leads are reversed. Disconnect power and reconnect meter leads for proper polarity.



*continued ...*

## **Cautions:**

1. The ceramic insulator of the igniter assembly should not be in or close to the flame.
2. The electrode assembly should not be disassembled and care must be used in making minor gap adjustment. The spark electrode should have a gap spacing of 1/8" - 3/16" [3.12± 0.81 mm]. If this spacing is not correct, the assembly must be carefully adjusted.
3. Exceeding the temperature limits can cause nuisance lockouts and premature electrode failure.

The control must be secured in an area that will experience a minimum of vibration and remain below the maximum operating temperature of 160°F.

## **18. SPARK IGNITION CIRCUIT**

The step-up transformer in the ignition control provides spark ignition at 30,000 volts [open circuit]. To check the spark ignition circuit, proceed as follows.

- 1 Shut off gas supply to the gas control
- 2 Disconnect the ignition cable at the ignition control stud terminal to isolate the circuit from the spark igniter or igniter/sensor
- 3 Prepare a short jumper lead, using heavily insulated wire such as ignition cable

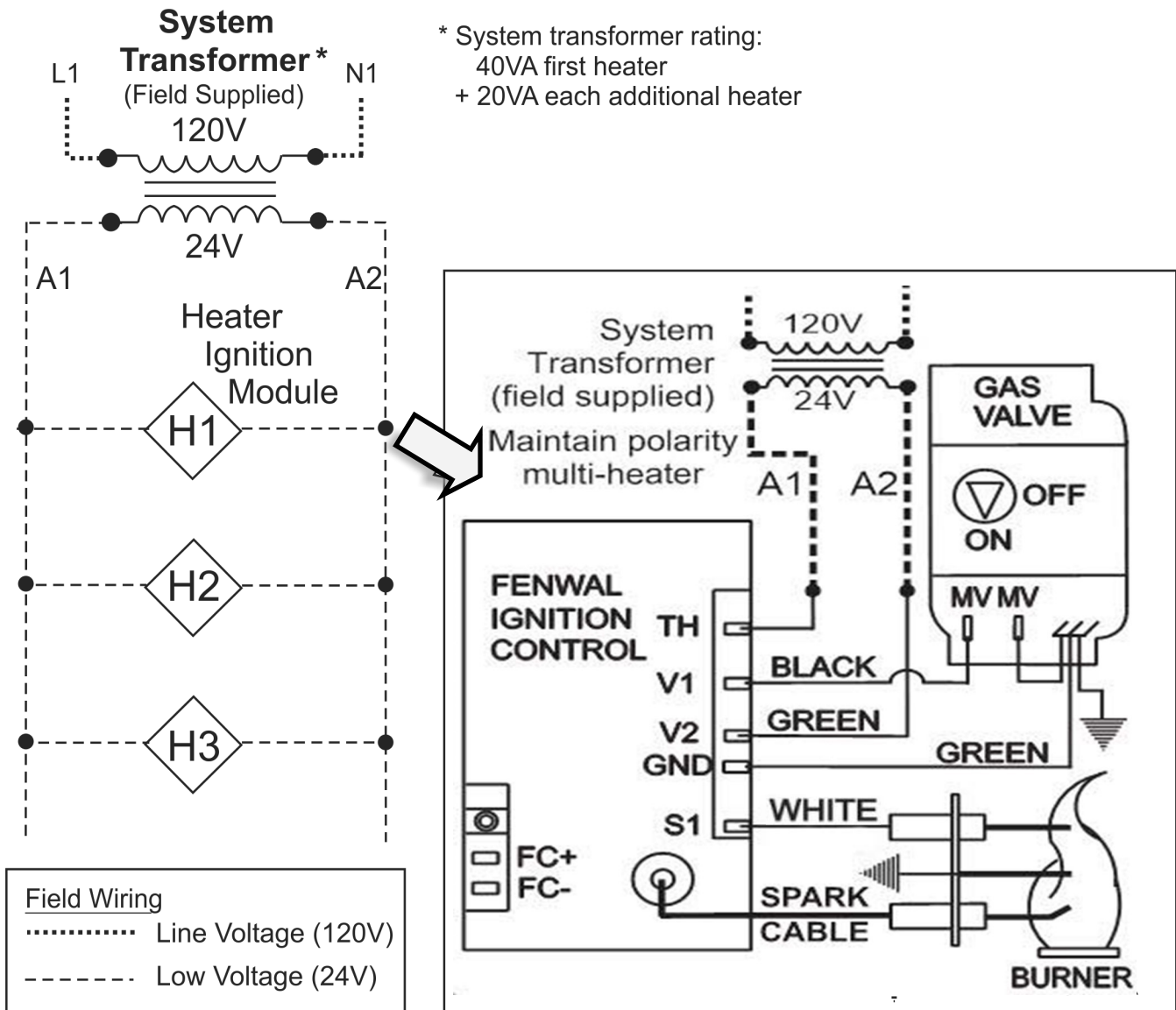
### **CAUTION**

**In the next step, DO NOT allow fingers to touch either the stripped end of the jumper or the stud terminal. This is a very high voltage circuit and electrical shock can result.**

- 1 Perform this test immediately upon energizing the system before the ignition control goes into safety lockout and interrupts the spark circuit. Touch one end of the jumper firmly to the ignition control GND terminal. [DO NOT remove the existing ground lead.] Slowly move the other end of the jumper wire toward the stud terminal on the ignition control to establish a spark.
- 2 Pull the wire away from the stud and note the length of gap at which spark discontinues.
- 3 A spark length of 1/8 in. [3mm] or more indicates satisfactory voltage output. If no arc can be established, or the maximum spark is less than 1/8 in. [3mm], and power to the ignition control input terminals was proved, replace the ignition control.

## 19. WIRING DIAGRAM: 2300 / IO 210 with Fenwal 35-60 DSI Control

If installing remote control kit JP-1235-RK refer to wiring diagram in the remote control manual



### Fenwal Control Terminal Designation

TH	Thermostat / 24V Supply Input
GND	System Ground
V1	Valve Power
V2	24V Supply Neutral
NC	Alarm
S1	Remote Flame Sensor

### Error Mode

Internal Control Failure
Flame with No Call for heat
Ignition Lockout

### LED Indication

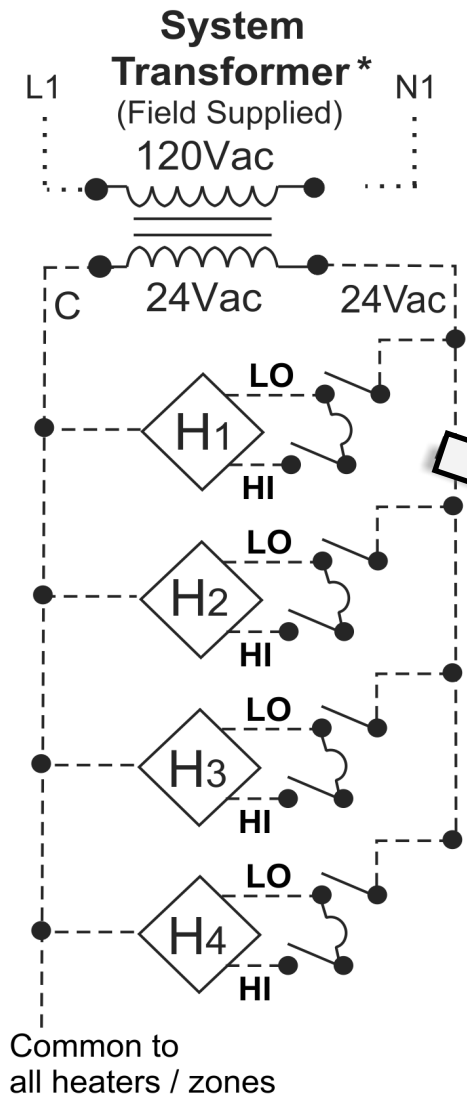
Steady on
2 flashes
3 flashes

### Fault Conditions:

The LED will flash on for 1/4 second, then off for 1/4 second during a fault condition. The pause between fault codes is 3 seconds.

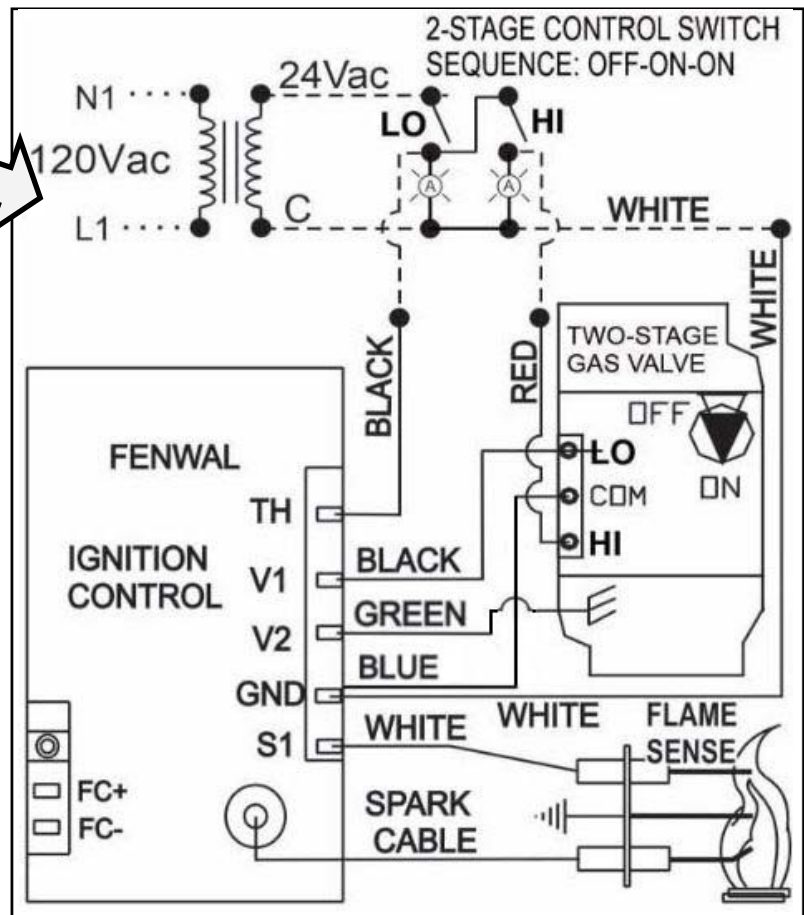
# 19-B. WIRING DIAGRAM: 2352 / IO-252 Two-Stage: Fenwal 35-60 DSI

NOTE: LOW STAGE SWITCH MUST BE ACTIVATED FOR HIGH STAGE OPERATION



\* System transformer capacity:  
40VA first heater  
+ 20VA each additional heater

2-STAGE CONTROL: SWITCH/PLATE ASSEMBLIES  
JM-0201-TS SINGLE SWITCH/PLATE ASSEMBLY - 2 STAGE  
JM-0202-TS DOUBLE SWITCH/PLATE ASSEMBLY - 2 STAGE  
JM-0203-TS TRIPLE SWITCH/PLATE ASSEMBLY - 2 STAGE



**Field Wiring**  
..... Line Voltage (120V)  
----- Low Voltage (24V)

Fenwal Control Terminal Designation	
TH	Thermostat / 24V Supply Input
GND	System Ground
V1	Valve Power
V2	24V Supply Neutral
NC	Alarm
S1	Remote Flame Sensor

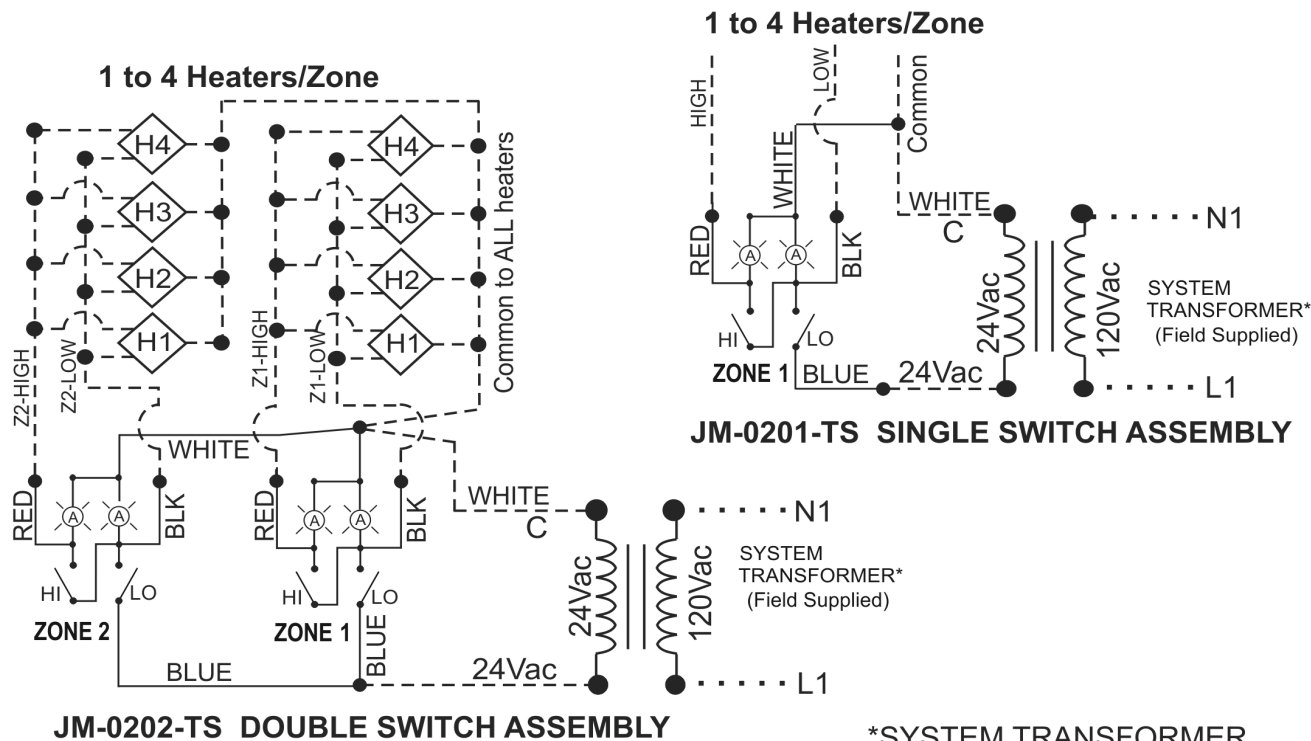
Error Mode	LED Indication
Internal Control Failure	Steady on
Flame with No Call for heat	2 flashes
Ignition Lockout	3 flashes

**Fault Conditions:**  
The LED will flash on for 1/4 second, then off for 1/4 second during a fault condition. The pause between fault codes is 3 seconds.

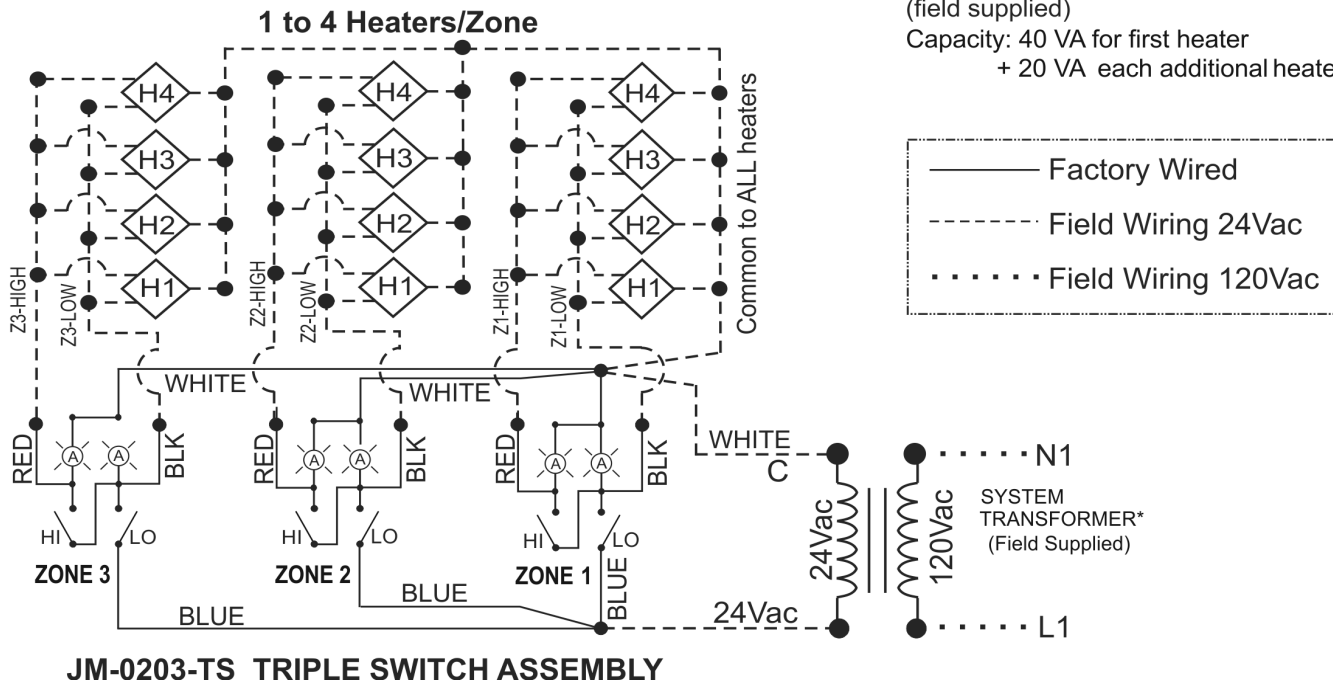
# 18-C. WIRING DIAGRAM: Two-Stage Switch Control

## 2-STAGE PATIO CONTROL SWITCH ASSEMBLY WIRING

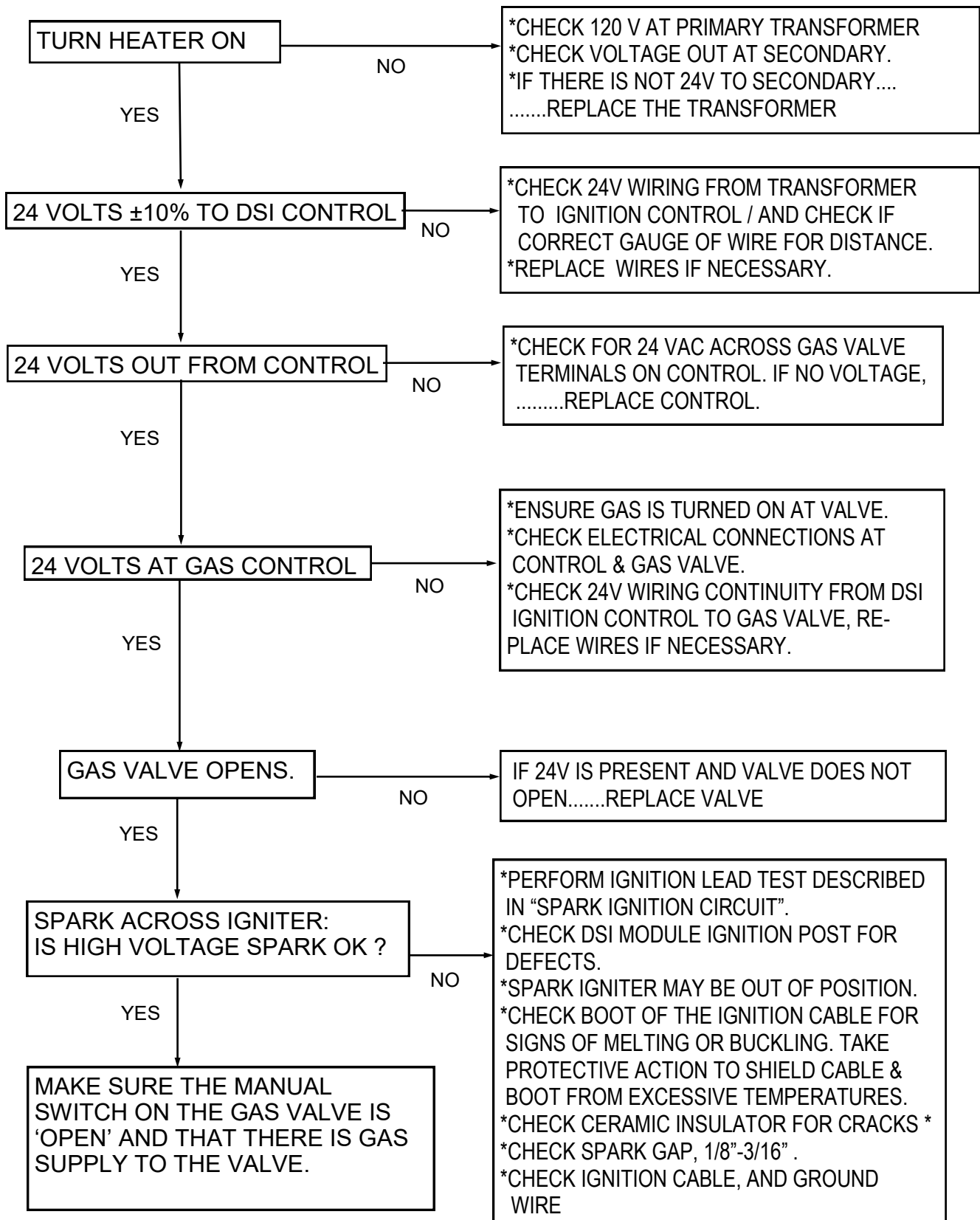
- Control from 1 to 4 heaters in a zone with each switch
- 2-Stage switch sequence required: OFF-ON-ON
- LOW STAGE SWITCH MUST BE ACTIVATED FOR HIGH STAGE OPERATION
- 3-Wire from first switch provides common (24Vac) to all heaters
- 2-Wire from additional switches provides low / high stage control

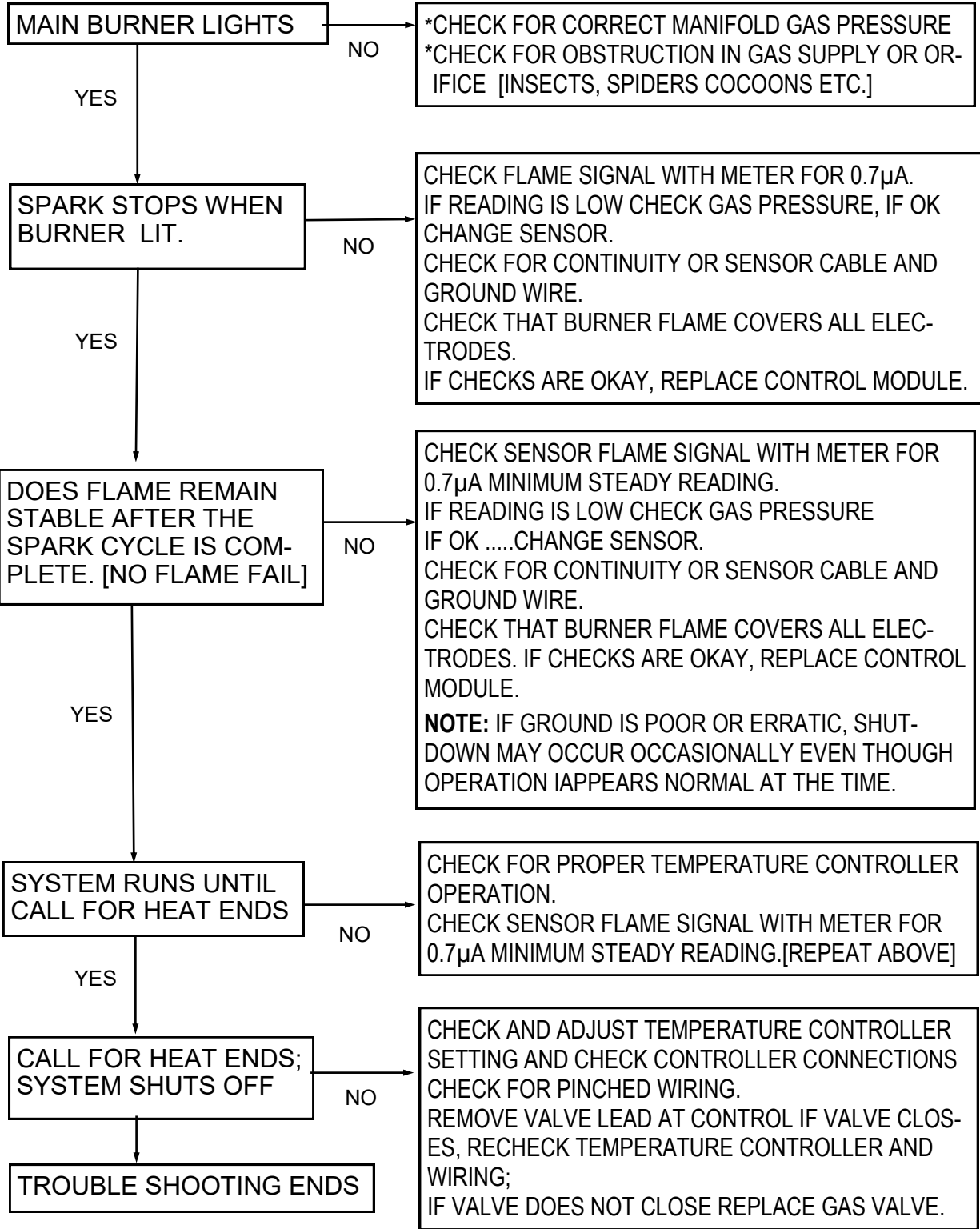


\*SYSTEM TRANSFORMER  
(field supplied)  
Capacity: 40 VA for first heater  
+ 20 VA each additional heater



## 20. TROUBLESHOOTING GUIDE





**NOTE: IF CONTROL GOES INTO LOCKOUT, THE SYSTEM CAN BE RESET BY INTERRUPTING THE POWER SOURCE**

## 21. COMMISSIONING REPORT

This heater has been factory fired and tested prior to shipment. However, it is not a 'Plug-in' appliance. **Commissioning and field adjustment to correct settings is required.**

**COMPLETE THIS COMMISSIONING REPORT AND  
FILE THIS MANUAL AT SITE FOR FUTURE REFERENCE**

**INSTRUCT THE END USER THAT THIS MANUAL MUST BE KEPT SECURE**

**A QUALIFIED SERVICE TECHNICIAN CALLING FOR TECHNICAL SUPPORT  
MUST PROVIDE THE INFORMATION FROM THE  
COMPLETED COMMISSIONING REPORT**

**TECHNICAL SUPPORT: 1-877-446-3727  
BUSINESS HOURS: 8:30 a.m. to 5:00 p.m. Eastern time**

### **COMMISSIONING REPORT AS PER I&O MANUAL AND LOCAL/NATIONAL CODES**

CONTRACTOR: \_\_\_\_\_

STREET: \_\_\_\_\_

CITY: \_\_\_\_\_ STATE/PROV: \_\_\_\_\_ ZIP: \_\_\_\_\_

PHONE: \_\_\_\_\_ CELL: \_\_\_\_\_

JOB NAME: \_\_\_\_\_

CITY: \_\_\_\_\_ STATE/PROV: \_\_\_\_\_

HEATER MODEL NUMBER : \_\_\_\_\_  
*Located on burner rating plate*

HEATER SERIAL NUMBER : \_\_\_\_\_  
*Located on burner rating plate*

*Technical commissioning report continues next page ....*

**HEATER COMMISSIONING TECHNICAL REPORT  
TO BE COMPLETED BY QUALIFIED GAS FITTER INSTALLER**

TYPE OF GAS	NG	<input type="checkbox"/>	LP	<input type="checkbox"/>
HEATER IS EXPOSED TO CHEMICAL OR CORROSIVE ATMOSPHERE	YES	<input type="checkbox"/>	NO	<input type="checkbox"/>
OPEN COMBUSTION IS COMPATIBLE WITH THE INSTALLED LOCATION	YES	<input type="checkbox"/>	NO	<input type="checkbox"/>
MINIMUM CLEARANCES CONFORM TO REQUIREMENTS OF THIS MANUAL	YES	<input type="checkbox"/>	NO	<input type="checkbox"/>
WHAT IS THE ALTITUDE OF THIS PROJECT LOCATION ABOVE SEA LEVEL	<input type="text"/>		FEET	<input type="text"/>
■ IS ALTITUDE ADJUSTMENT REQUIRED? [See Section 21 next page]	YES	<input type="checkbox"/>	NO	<input type="checkbox"/>
THE HEATER IS INSTALLED LEVEL ON THE LONG AXIS	YES	<input type="checkbox"/>	NO	<input type="checkbox"/>
THE GAS SUPPLY PIPING IS ADEQUATELY SIZED FOR SYSTEM VOLUME	YES	<input type="checkbox"/>	NO	<input type="checkbox"/>
GAS SUPPLY LINES AND BRANCHES HAVE BEEN PURGED OF AIR	YES	<input type="checkbox"/>	NO	<input type="checkbox"/>
INLET GAS SUPPLY PRESSURE WITH ALL HEATERS OPERATING	<input type="text"/>		" WC	<input type="text"/>
MANIFOLD PRESSURE WITH HEATER OPERATING	<input type="text"/>		" WC	<input type="text"/>
WIRING POLARITY IS MAINTAINED AT EACH IGNITION MODULE IN SYSTEM	YES	<input type="checkbox"/>	NO	<input type="checkbox"/>
VOLTAGE READING AT IGNITION MODULE	<input type="text"/>		VOLTS	<input type="text"/>
FLAME SIGNAL STRENGTH FROM SENSOR [µA microamps]	<input type="text"/>		µA	<input type="text"/>
IS THE HEATER CONTROLLED BY A THERMOSTAT	YES	<input type="checkbox"/>	NO	<input type="checkbox"/>
IS THE THERMOSTAT STRATEGICALLY LOCATED	YES	<input type="checkbox"/>	NO	<input type="checkbox"/>
QUANTITY OF HEATERS IN ZONE SUPPLIED BY SINGLE TRANSFORMER	<input type="text"/>		Total	<input type="text"/>
RATING OF THE ZONE TRANSFORMER [VA Volt-Amps]	<input type="text"/>		VA	<input type="text"/>
TOTAL LENGTH OF LOW VOLTAGE WIRING	<input type="text"/>		FEET	<input type="text"/>
GAUGE OF THE LOW VOLTAGE WIRING	<input type="text"/>		GAUGE	<input type="text"/>
IS THE HEATER ELECTRICALLY GROUNDED	YES	<input type="checkbox"/>	NO	<input type="checkbox"/>
THIS HEATER TEST FIRED WITHOUT MALFUNCTION	YES	<input type="checkbox"/>	NO	<input type="checkbox"/>

- **COMPLETE THIS COMMISSIONING REPORT AND FILE THIS MANUAL AT SITE FOR FUTURE REFERENCE**
- **INSTRUCT THE END USER THAT THIS MANUAL MUST BE KEPT SECURE**
- **A QUALIFIED SERVICE TECHNICIAN CALLING FOR TECHNICAL SUPPORT MUST PROVIDE THE INFORMATION FROM THE COMPLETED COMMISSIONING REPORT**

## 22. HIGH ALTITUDE INSTALLATION / DERATION

***This heater not to be installed at altitude above 6,800 feet.***

**USA:** The factory installed orifice for this appliance is approved for altitudes **zero to 2000 feet** above sea level. When installed **above 2000 feet**, refer to information below.

**Canada:** The factory installed orifice for this appliance is approved for altitudes **zero to 4500 feet** above sea level. When installed **above 4500 feet**, refer to information below.

When this appliance is installed above the standard altitude stipulated the input must be de-rated by 4% for each 1000 ft above sea level. The orifice must be changed according to the chart below - confirm the correct model. Check with your local utility regarding the gas supply and the de-rating of this appliance.

MODEL	USA ORIFICE DERATION FOR USE AT ALTITUDES ABOVE [FEET] Gas Orifice Drill Size <sup>1</sup> / Part #						DO NOT INSTALL AT ALTI- TUDE ABOVE 6,800 FEET
	Supplied	USA Only					
	0	> 2000	> 3000	> 4000	> 5000	> 6000	
2312 / IO-212 NG	45 DMS JX-0745-DM	46 DMS JX-0746-DM	2 MM JX-0720-MM	47 DMS JX-0747-DM	48 DMS JX-0748-DM	48 DMS JX-0748-DM	
2312 / IO-212 LPG	54 DMS JX-0754-DM	54 DMS JX-0754-DM	55 DMS JX-0755-DM	55 DMS JX-0755-DM	55 DMS JX-0755-DM	55 DMS JX-0755-DM	
2313 / IO-213 NG	38 DMS JX-0738-DM	39 DMS JX-0739-DM	40 DMS JX-0740-DM	41 DMS JX-0741-DM	41 DMS JX-0741-DM	42 DMS JX-0742-DM	
2313 / IO-213 LPG	50 DMS JX-0750-DM	51 DMS JX-0751-DM	51 DMS JX-0751-DM	51 DMS JX-0751-DM	51 DMS JX-0751-DM	52 DMS JX-0752-DM	
2352 / IO-252 NG	31 DMS JX-0731-DM	32 DMS JX-0732-DM	32 DMS JX-0732-DM	32 DMS JX-0732-DM	33 DMS JX-0733-DM	34 DMS JX-0734-DM	

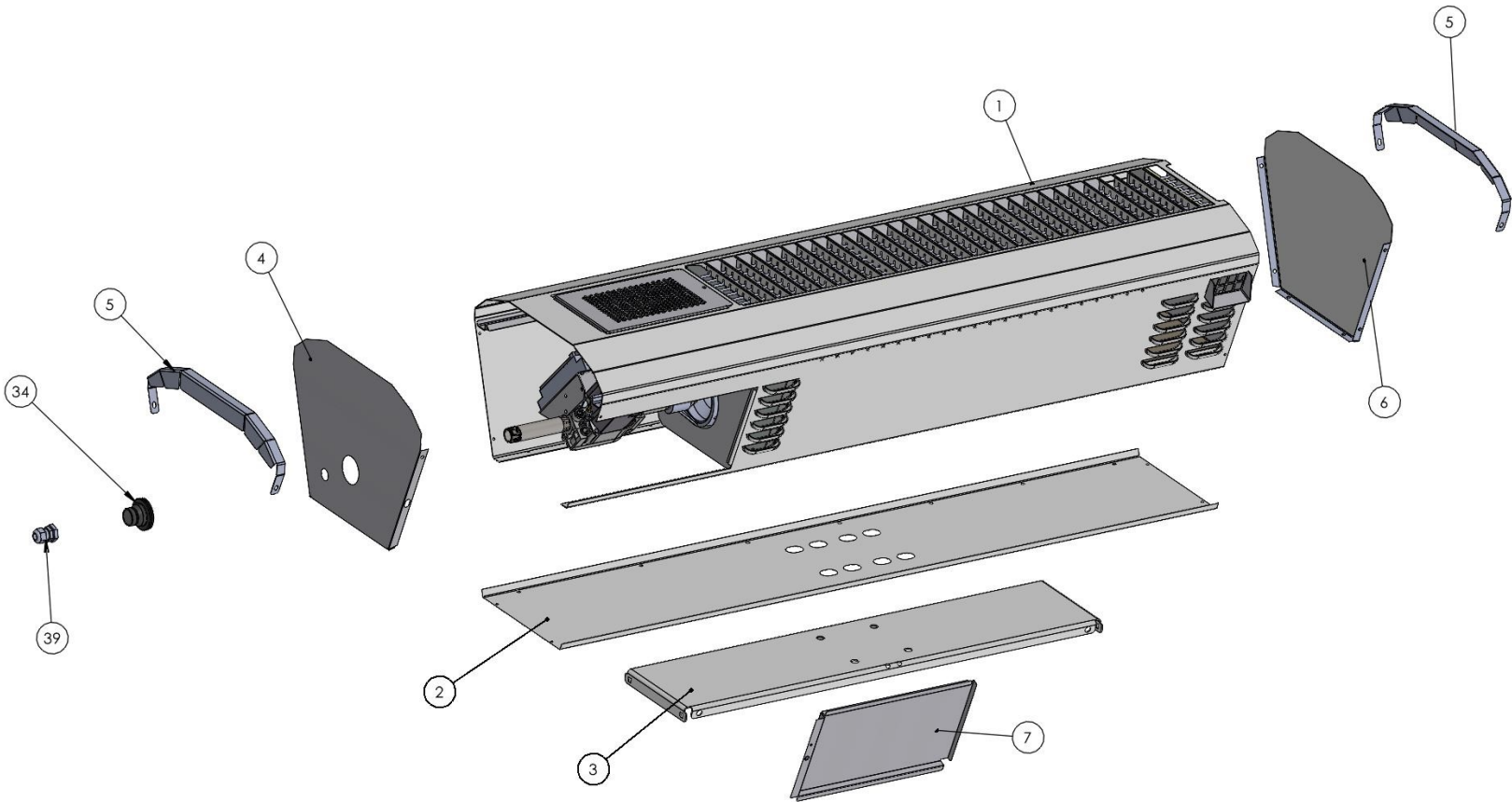
<sup>1</sup> Per ANSI Z223.1 [NFPA 54]

MODEL	CANADA ORIFICE DERATION FOR USE AT ALTITUDES ABOVE [FEET] Gas Orifice Drill Size / Part #				DO NOT INSTALL AT ALTI- TUDE ABOVE 6,800 FEET
	Supplied	CANADA Only			
	0	> 4500	> 5000	> 6000	
2312 / IO-212 NG	45 DMS JX-0745-DM	47 DMS JX-0747-DM	48 DMS JX-0748-DM	48 DMS JX-0748-DM	
2312 / IO-212 LPG	54 DMS JX-0754-DM	55 DMS JX-0755-DM	55 DMS JX-0755-DM	55 DMS JX-0755-DM	
2313 / IO-213 NG	38 DMS JX-0738-DM	41 DMS JX-0741-DM	41 DMS JX-0741-DM	42 DMS JX-0742-DM	
2313 / IO-213 LPG	50 DMS JX-0750-DM	51 DMS JX-0751-DM	51 DMS JX-0751-DM	52 DMS JX-0752-DM	
2352 / IO-252 NG	31 DMS JX-0731-DM	32 DMS JX-0732-DM	33 DMS JX-0733-DM	34 DMS JX-0734-DM	

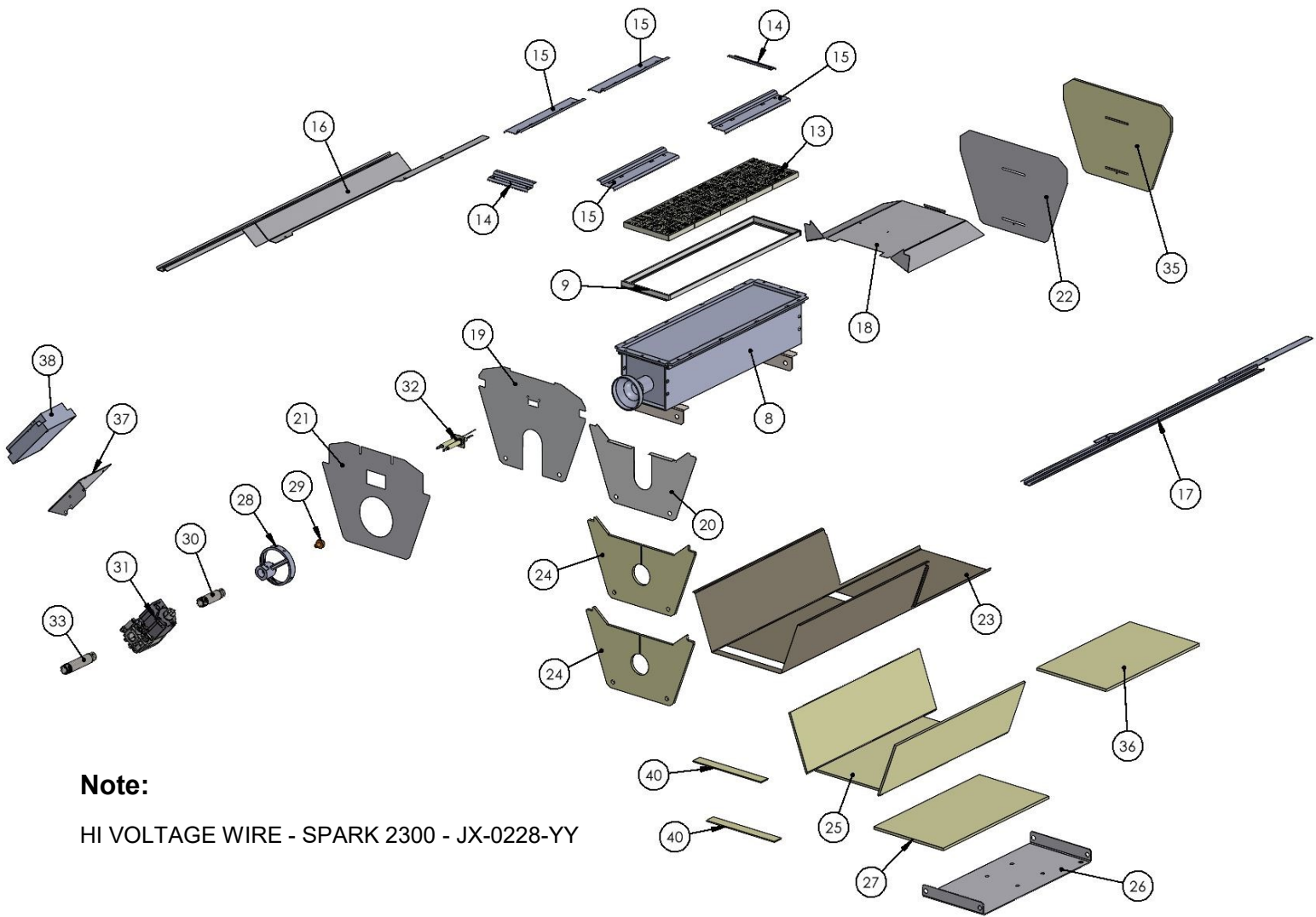
**CANADA:** For installations higher than 4500 ft the installer shall consult the local provincial authorities for exact orifice size replacements. The chart above is meant as a guideline only.

## 23. Replacement Parts List

### Replacement parts for the 2312 / IO-212 and 2313/ IO-213



STANDARD BLACK FINISH - ENCLOSURE PARTS		ORDER QUANTITY	2312 / IO-212	2313 / IO-213
#	PART NAME		PART #	PART #
1	PATIOSCHWANK SCREEN [316 SS]	1	JP-2312-SS	JP-2315-SS
2	PATIOSCHWANK TOP COVER S/S	1	JP-S312-CV	JP-S313-CV
3	PATIOSCHWANK 2300 HANGING SUPPORT S/S	1	JP-S300-HS	JP-S300-HS
4	PATIOSCHWANK 2300 PIPE END PLATE S/S	1	JP-S300-PE	JP-S300-PE
5	PATIOSCHWANK 2300 SCREEN RETAINER [316 SS]	2	JP-2300-SR	JP-2300-SR
6	PATIOSCHWANK 2300 END PLATE S/S	1	JP-S300-EP	JP-S300-EP
7	PATIOSCHWANK 2300 SERVICE DOOR [316 S/S]	1	JP-S300-SD	JP-S300-SD
34	LIQUID TIGHT FITTING PGB9	1	JP-2036-XX	JP-2036-XX
39	PATIO GROMMET INLET GAS 1/2"	1	JP-2101-XX	JP-2101-XX



**Note:**

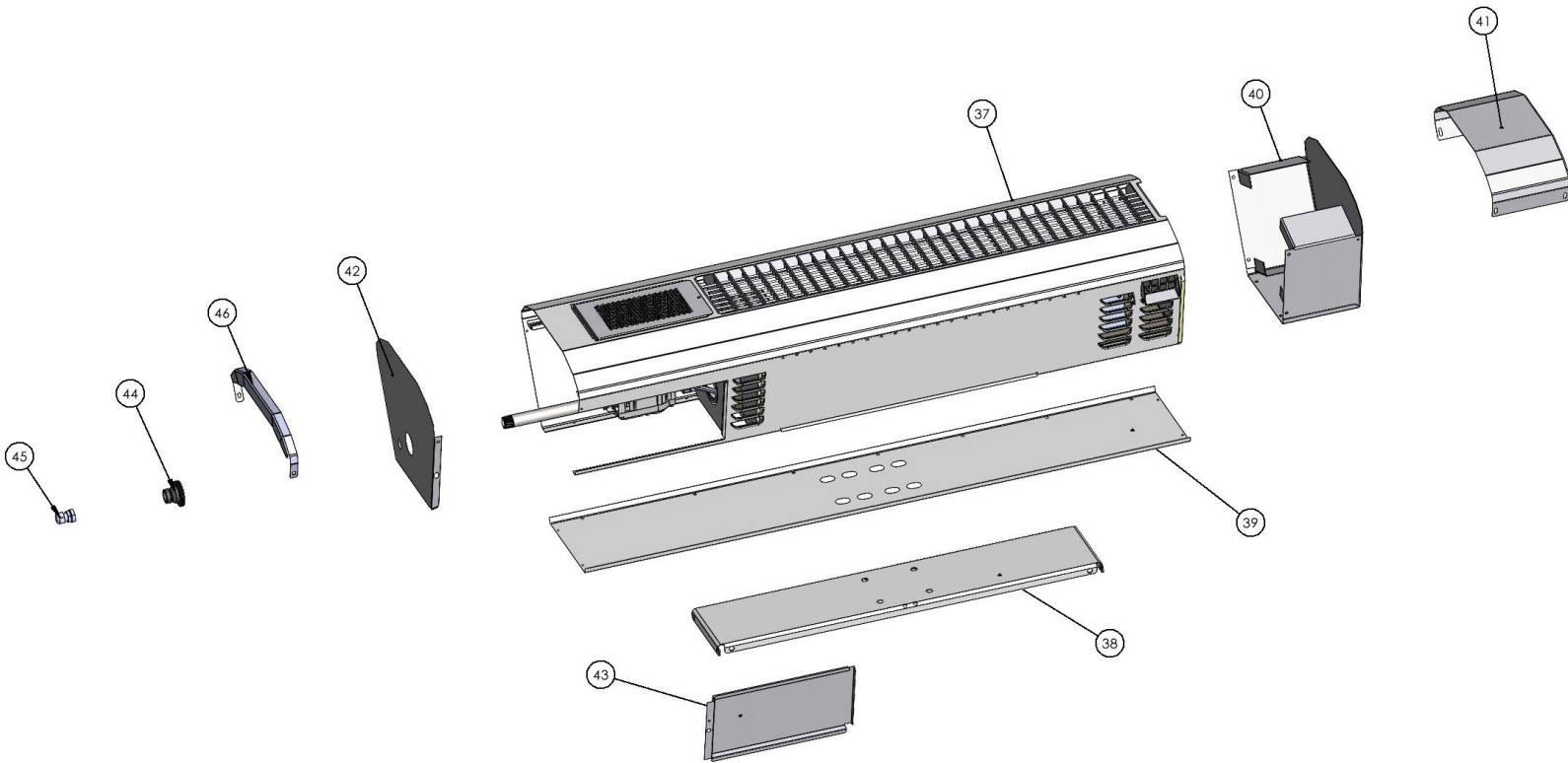
HI VOLTAGE WIRE - SPARK 2300 - JX-0228-YY

REPLACEMENT PARTS LIST		ORDER QUANTITY	2312 / IO-212	2313 / IO-213
#	PART NAME		PART #	PART #
8	BURNER ONLY - ECO 06-X	1	JX-X025-BO	-
8	BURNER ONLY - ECO 10-X	1	-	JX-X037-BO
9	GASKET SET - AGRO 315	1	JX-0245-AA	-
9	GASKET SET - ECO 10	1	-	JX-0245-XX
13	TILE - CERAMIC CERASCHWANK 144 EFFECT	Each	JO-0370-CX <i>Qty 3 Tiles</i>	JO-0370-CX <i>Qty 5 Tiles</i>
14	TILE RETAINER END - ECO JR IL [ONE EACH END]	Each	JX-0243-XX	JX-0243-XX
15	TILE RETAINER 275mm - ECO-X 6, 18, 36 IL-X 25, 75, 150 [ONE EACH SIDE]	Each	JX-0243-XA	-
15	TILE RETAINER 230mm - ECO-X 10 IL-X 37 [TWO EACH SIDE]	Each	-	JX-0243-XB
16	PATIOSCHWANK REFLECTOR RIGHT [316 S/S]		JP-S312-RS-R	JP-S313-RS-R

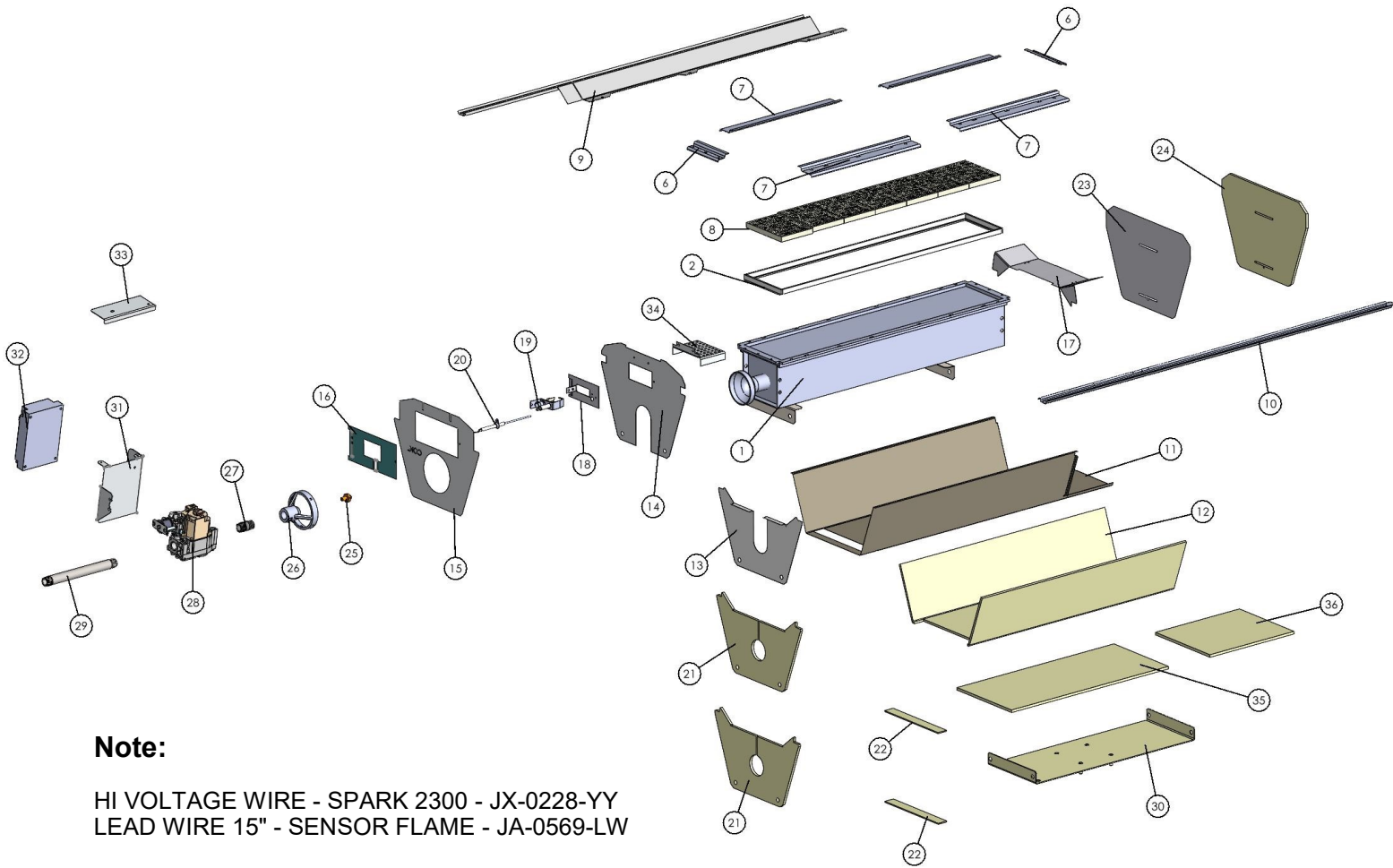
REPLACEMENT PARTS LIST		ORDER QUAN- TITY	2312 / IO-212	2313 / IO-213
#	PART NAME		PART #	PART #
17	PATIOSCHWANK REFLECTOR LEFT [316 S/S]	1	JP-S312-RS-L	JP-S313-RS-L
18	PATIOSCHWANK HORIZONTAL PLATE [316 S/S]	1	JP-S312-HP	JP-S313-HP
19	PATIOSCHWANK 2300 IGNITER PLATE [304 S/S]	1	JP-2300-IG	JP-2300-IG
20	PATIOSCHWANK 2300 SEPARATOR PLATE	1	JP-2300-SP	JP-2300-SP
21	PATIOSCHWANK 2300 VENTURI PLATE	1	JP-2300-VP	JP-2300-VP
22	PATIOSCHWANK 2300 INSULATED END PLATE	1	JP-2300-IE	JP-2300-IE
23	PATIOSCHWANK INSULATION PLATE	1	JP-2312-IP	JP-2313-IP
24	INSULATION 2300 VENTURI [1/4" x 7-3/16" x 11-7/8"]	2	JP-2300-VN	JP-2300-VN
25	INSULATION 2312 HORIZONTAL [1/4" x 11" x 18-7/8"]	1	JP-2312-TN	-
25	INSULATION 2313 HORIZONTAL [1/4" x 18" x 18-7/8"]	1	-	JP-2313-TN
26	PATIOSCHWANK U BRACKET	1	JP-2312-UB	JP-2313-UB
27	INSULATION 2312 TOP [1/4" x 7-3/4" x 8-3/4"]	1	JP-2312-NB	JP-2312-NB
28	ECOSCHWANK ORIFICE HOLDER	1	JX-0210-XX	JX-0210-XX
29	LUMINOUS ORIFICE [#45 DMS] - N.G	1	JX-0745-DM [NG]	-
29	LUMINOUS ORIFICE [#38 DMS] - N.G	1	-	JX-0738-DM [NG]
29	LUMINOUS ORIFICE [#54 DMS] - L.P	1	JX-0754-DM [LP]	-
29	LUMINOUS ORIFICE [#50 DMS] - L.P	1	-	JX-0750-DM [LP]
30	NIPPLE - 1/2" X 3"	1	JX-0209-XZ	JX-0209-XZ
31	GAS VALVE - VR8205A2065B 5" W.C. - N.G.	1	JL-0701-XX [NG]	JL-0701-XX [NG]
31	GAS VALVE - VR8105M2833B/VR8205A2081B 10" W.C. - L.P.	1	JL-0703-LF [LP]	JL-0703-AA [LP]
32	IGNITOR/SENSOR PRIMO/SUPRA CW 18" SEN. WIRE	1	JO-0305-XX	JO-0305-XX
33	NIPPLE GALVINIZED 1/2" X 4"	1	JS-0590-GA	JS-0590-GA
35	INSULATION 2300 END [1/4" x 8-3/8" x 11-7/8"]	1	JP-2300-EN	JP-2300-EN
36	INSULATION 2312 TOP [1/4" x 7-3/4" x 7-1/4"]	1	JP-2312-NC	-
36	INSULATION 2313 TOP [1/4" x 7-3/4" x 13"]	1	-	JP-2313-NC
37	D.S.I. CONTROL BRACKET	1	JX-0206-XX	JX-0206-XX
38	DSI - FENWAL - 35-605960-099 - 24V - LUMINOUS	1	JP-2573-FW	JP-2573-FW
40	INSULATION 2300 TOP [1/4" x 1" x 7-1/2"]	2	-	JP-2300-NA

## 23. Replacement Parts List Con't

### Replacement parts for the 2352 / IO-252



STANDARD BLACK FINISH - ENCLOSURE PARTS		ORDER QUANTITY	2352 / IO-252
#	PART NAME		PART #
37	PATIOSCHWANK 2313 / 2352 SCREEN [316 SS]	1	JP-2315-SS
38	PATIOSCHWANK 2300 HANGING SUPPORT S/S	1	JP-S300-HS
39	PATIOSCHWANK 2313 TOP COVER S/S	1	JP-S313-CV
40	PATIOSCHWANK 2352 EXTENDED END PLATE [316 S/S]	1	JP-S352-EP
41	PATIOSCHWANK 2352 SCREEN RETAINER [316 SS]	1	JP-2352-SR
42	PATIOSCHWANK 2300 PIPE END PLATE S/S	1	JP-S300-PE
43	PATIOSCHWANK 2300 SERVICE DOOR [316 S/S]	1	JP-S300-SD
44	LIQUID TIGHT FITTING PGB9	1	JP-2036-XX
45	PATIO GROMMET INLET GAS 1/2"	1	JP-2101-XX
46	PATIOSCHWANK 2300 SCREEN RETAINER [316 SS]	1	JP-2300-SR



**Note:**

HI VOLTAGE WIRE - SPARK 2300 - JX-0228-YY  
 LEAD WIRE 15" - SENSOR FLAME - JA-0569-LW

REPLACEMENT PARTS LIST		ORDER QUANTITY	2352 / IO-252
#	PART NAME		PART #
1	BURNER ONLY - ECO 13-X	1	JX-X050-BO
2	GASKET SET - ECO 13	1	JX-0246-XX
6	TILE RETAINER END - ECO JR IL [ONE EACH END]	Each	JX-0243-XX
7	TILE RETAINER 32mm - ECO-X 13, 18, 26/ IL-X 50, 75, 100 [TWO EACH SIDE]	Each	JX-0243-XC
8	TILE -CERAMICCERASCHWANK 144 EFFECT	Each	JO-0370-CX Qty 7 Tiles
9	PATIOSCHWANK 2315 REFLECTOR - RIGHT [316 S/S]	1	JP-2315-RS-R
10	PATIOSCHWANK 2315 REFLECTOR - LEFT [316 S/S]	1	JP-2315-RS-L
11	PATIOSCHWANK 2315 INSULATION PLATE	1	JP-2315-IP
12	INSULATION 2315 HORIZONTAL [1/4" x 23-1/2" x 18-7/8"]	1	JP-2315-TN
13	PATIOSCHWANK 2300 SEPARATOR PLATE	1	JP-2300-SP

REPLACEMENT PARTS LIST		ORDER QUANTITY	2352 / IO-252
#	PART NAME		PART #
14	PATIOSCHWANK 2352 ACCESS IGNITER PLATE	1	JP-2352-IG-A
15	PATIOSCHWANK 2352 ACCESS VENTURI PLATE	1	JP-2352-VP-A
16	PATIOSCHWANK 2352 ACCESS VENTURI BRACKET	1	JP-2352-VP-B
17	PATIOSCHWANK 2315 HORIZONTAL PLATE [316 S/S]	1	JP-S315-HP
18	PILOT - IGNITER & SENSOR BRACKET FOR - Q3451B HW IGNITER	1	JX-0205-BK-B
19	PILOT BURNER ASSEMBLY c/w SPARK WIRE & INSULATION - 2100/2300	1	JX-0205-XX
20	SENSOR FLAME - 5.75"	1	JA-0569-FS
21	INSULATION 2300 VENTURI [1/4" x 7-3/16" x 11-7/8"]	2	JP-2300-VN
22	INSULATION 2300 TOP [1/4" x 1" x 7-1/2"]	2	JP-2300-NA
23	PATIOSCHWANK 2300 INSULATED END PLATE	1	JP-2300-IE
24	INSULATION 2300 END [1/4" x 8-3/8" x 11-7/8"]	1	JP-2300-EN
25	LUMINOUS ORIFICE [#31 DMS]	1	JX-0731-DM
26	ECOSCHWANK ORIFICE HOLDER	1	JX-0210-XX
27	NIPPLE - 1/2" X 2" WITH THREADED HOLE 2100	1	JX-0209-ZZ
28	GAS VALVE VR8205Q2969 NG TWO STAGE 5"-3" W.C.	1	JA-0506-TS
29	NIPPLE GALVINIZED 1/2" X 6"	1	JX-0209-GA
30	PATIOSCHWANK 2315 U BRACKET	1	JP-2315-UB
31	D.S.I. CONTROL BRACKET 2352	1	JX-0206-52
32	DSI - FENWAL - 35-605960-099 - 24V - LUMINOUS	1	JP-2573-FW
33	D.S.I. CONTROL BRACKET 2352 WATER SHED	1	JX-0206-52-WS
34	PILOT FLAME SHIELD 2100	1	JX-0205-FS
35	INSULATION 2315 TOP [1/4" x 7-3/4" x 18-1/4"]	1	JP-2315-NB
36	INSULATION 2315 TOP [1/4" x 7-3/4" x 9-3/4"]	1	JP-2315-NC



**LIMITED WARRANTY CERTIFICATE**



**GAS-FIRED INFRA-RED PATIO HEATERS: 2300 / IO 210SERIES**

The Manufacturer warrants that this product is free from defects in material or workmanship under normal use and service subject to the terms of this document.

**ONE YEAR WARRANTY**

Subject to the conditions and limitations stated herein, during the term of this limited warranty, we will supply any component part [at our option a new or repaired component part] of the heater as defined below, excluding any labor, which the Manufacturer's examination determines to be defective in workmanship or material for a period of one year [1 year] from the date of installation, unless otherwise specified below. This warranty applies to the heater's original owner, and subsequent transferees and only if the unit is installed and operated in accordance with the printed instructions accompanying the unit and in compliance with all applicable installation codes and good trade practices.

**BURNER AND CERAMIC TILES - THREE YEAR WARRANTY**

The Manufacturer warrants the burner assembly and the ceramic tiles for a period of three years [3 years].

**WHAT IS NOT COVERED**

The Manufacturer shall not be responsible for any expenses, including service, labor, diagnosis, analysis, material or transportation charges incurred during removal or reinstallation of this product, or any of its components or parts. All labor or service charges shall be paid by the owner. This warranty does not cover heating products improperly installed, misused, exposed to or damaged by negligence, accident, corrosive or contaminating atmosphere, water, excessive thermal shock, impact, abrasion, normal wear due to use, alteration or operation contrary to the owner's manual or if the serial number has been altered, defaced or removed. This warranty shall not apply if the input to the heating product exceeds by more than 2% of the rated input on the rating plate. The Manufacturer shall not be liable for any default or delay in performance by its warranty caused by any contingency beyond its control, including war, government restrictions, or restraints, strikes, fire, flood, acts of God, or short or reduced supply of raw materials or products.

**WARRANTY PROCEDURE**

To establish the installation date for any purpose under this Limited Warranty, you must retain the original records that can establish the installation date of your unit. If you do not provide such documents, the start date of the term of this Limited Warranty will be based upon the date of unit manufacture, plus thirty [30] days. Failure to maintain the equipment through regular annual service maintenance by a qualified service technician shall void the warranty.

**LIMITATIONS AND EXCLUSIONS**

This document contains all warranties made by the Manufacturer and may not be varied, altered or extended by any person. There are no promises, or agreements extending from the Manufacturer other than the statements contained herein. THIS WARRANTY IS IN LIEU OF ALL WARRANTIES EXPRESSED OR IMPLIED, TO THE EXTENT AUTHORIZED BY THE LAWS OF THE JURISDICTION, INCLUDING SPECIFICALLY THE WARRANTIES OR MERCHANTABILITY OF FITNESS FOR A PARTICULAR PURPOSE.

It is understood and agreed that the Manufacturer's obligation hereunder is limited to repairing or replacing parts determined to be defective as stated above. In no event shall the Manufacturer be responsible for any alleged personal injuries or other special, incidental or consequential damages. As to property damages, contract, tort or other claim the Manufacturer's responsibility shall not exceed the purchase price paid for the product.

All replacement parts will be warranted for the unused portion of the warranty coverage period remaining on the applicable unit.

Some Authorities do not allow certain warranty exclusions or limitations on duration of warranty or the exclusions or limitations of incidental or consequential damages. In such cases, the above limitations or exclusions may not apply to you and are not intended to do so where prohibited by law. This warranty gives you specific legal rights. You may also have other rights which vary by jurisdiction.

**SCHWANK & INFRASAVE  
2 SCHWANK WAY, WAYNESBORO, GEORGIA. 30830  
6485 ORDAN DR MISSISSAUGA, ON, L5T 1X2**

**Ph: 1-877-686-3779  
www.SchwankGroup.com**

**Fax: 1-866-361-0523  
www.InfraSave.com**